

True touch control HD - Touch screen Display



Superior cooking results FAST!

- 2000W impingement enhances browning. Easily adjustable 0-100% fan speed
- 95° - 270°C (200° - 520°F) convection temperature range
- 3000W Infra-red radiant enhances toasting, browning, and crisping
- 2000 - 2200W dual side antenna feed microwave system heats quickly reduces cooking time

The MXP5221TLT cooks up to 15 times faster than conventional cooking so you can cook to order, minimise waste and reduce customer waiting times. The "One-touch" cooking provides consistent cooking, every time. In-built catalytic converter filters grease and odour from the air.



STANDARD FEATURES

- USB, WIFI, ethernet for menu management
- Two removable / cleanable air filters
- Non stick liners installed for easier cleaning
- Enamelled element cover / tray

OPTIONAL FEATURES

- Oven paddle
- Pizza Stone
- Non-stick basket
- Leg kit (102mm height)
- Panini Press

front view

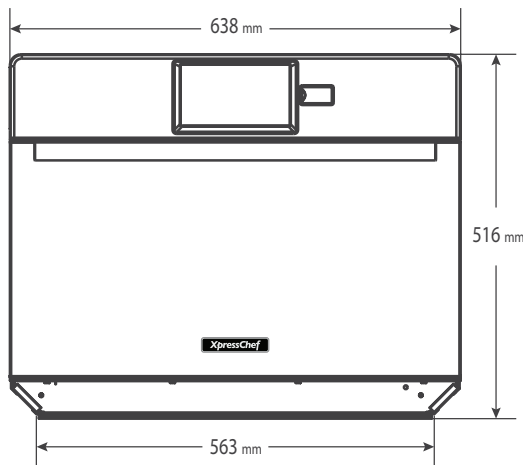

side view

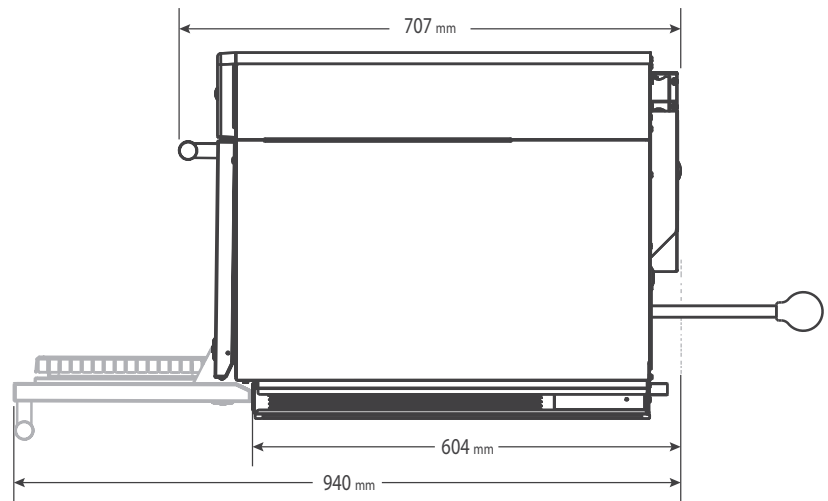

back view

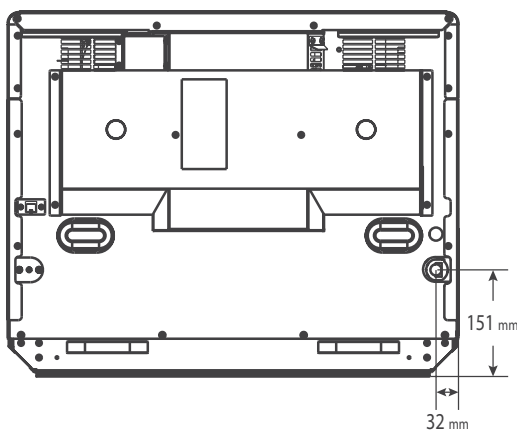

DIMENSIONS

External dimensions: 638W x 699D x 518H mm

Internal cavity: 406W x 381D x 254H mm

POWER SUPPLY

240V 50Hz 32A single phase, plugged

TECHNICAL DATA

Power output: 5800W Total
2000W Convection,
2200W Microwave,
3000W Infra-red radiant

Internal cavity volume: 39 litres

External cabinet finish: Stainless steel

Internal cavity finish: Stainless steel & Teflon liner (replaceable)

Memory programs: 360

Power levels: 11

Product weight: 68kg

Shipping weight: 79kg

Magnetrons: 2

Clearance: 51mm top & sides

SPECIFICATIONS ARE SUBJECT TO CHANGE WITHOUT NOTICE.

WA DEALER
PRACTICAL PRODUCTS PTY LTD

PH: 08 9302 1299
51 Paramount Dr Wangara WA 6065
sales@practicalproducts.com.au
www.practicalproducts.com.au