

TECHNICAL DATA SHEET FOR

# 50 Litre Planetary Mixer

## BM50AT3P

### STANDARD FEATURES

- Heavy duty construction
- Belt driven
- Long life gear box
- 3 fixed speeds
- Easy speed shifting
- 15 minute timer

### STANDARD ACCESSORIES

- Batter beater
- Dough hook
- Wire whisk
- 50 litre stainless steel bowl
- Wire safety guard
- Scraper



BM50AT3P with HUB attachment drive

### OPTIONAL ACCESSORIES

- BM50AT-06-003 HUB attachment drive (BM50AT3P)
- HL-G12SH Mincer
- HL-VS12A Slicer / Shredder
- BM50AT-12-001 Stainless steel bowl to suit 50 litre mixer
- BM50AT-12-002 Batter beater to suit 50 litre mixer
- BM50AT-12-003 AL hook to suit 50 litre mixer
- BM50AT-12-004 Stainless steel wire whip to suit 50 litre mixer
- BM50ATM Reduction kit 30 litre includes bowl, hook, beater and whisk

TECHNICAL DATA SHEET FOR

# 50 Litre Planetary Mixer BM50AT3P

**SPECIFICATIONS**

**Electrical Requirements**

400-415V, 3P+E, 50Hz, 1.312kW

**External Dimensions**

Width 590mm

Height 1232mm

Depth 688mm

**Nett Weight**

205kg



Australia  
www.moffat.com.au  
New Zealand  
www.moffat.co.nz

**Australia**  
Moffat Pty Limited  
Victoria/Tasmania  
740 Springvale Road  
Mulgrave, Victoria 3170  
Telephone 03-9518 3888  
Facsimile 03-9518 3833  
vsales@moffat.com.au  
New South Wales  
Telephone 02-8833 4111  
nswsales@moffat.com.au  
South Australia  
Telephone 03-9518 3888  
vsales@moffat.com.au  
Queensland  
Telephone 07-3630 8600  
qldsales@moffat.com.au  
Western Australia  
Telephone 08-9202 6820  
bgarcia@moffat.com.au

**New Zealand**  
Moffat Limited  
Christchurch  
16 Osborne Street  
Christchurch 8011  
Telephone 03-389 1007  
Facsimile 03-389 1276  
sales@moffat.co.nz  
Auckland  
Telephone 09-574 3150  
sales@moffat.co.nz

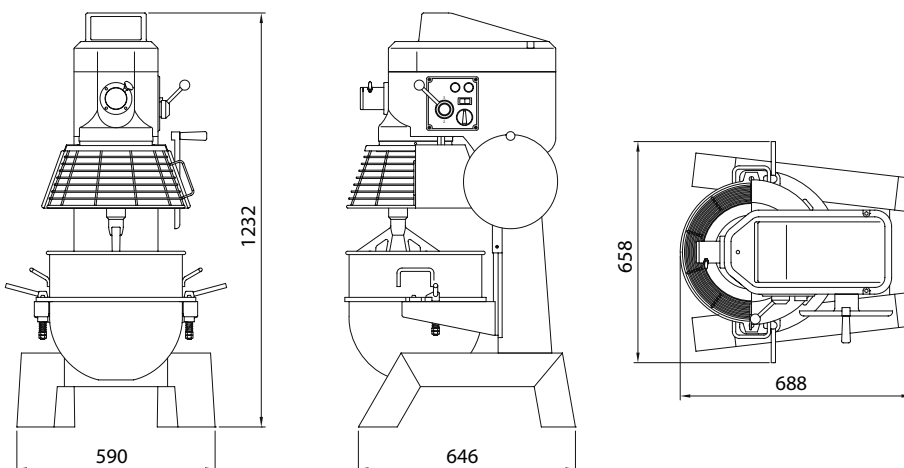

In line with policy to continually develop and improve its products, Moffat Limited reserves the right to change specifications and design without notice.

