



Eswood

Professional

Glasswasher

IW3N

Professional Undercounter Glasswasher



Eswood

Professional Undercounter Glasswasher

Eswood IW3N incorporates a powerful wash pump and boost heater to maintain optimum wash quality and provide fast turnaround of up to 1800 glasses per hour.

Simple push-button controls activate the fully automatic operation with either a hot cycle or a hot cycle followed by a cooling cycle.

New digital temperature display for easy temperature recording in controlled environments.

The IW3N conforms to the highest of health and sanitary standards, meeting FSANZ safe food codes and certifications in HACCP and WaterMark.

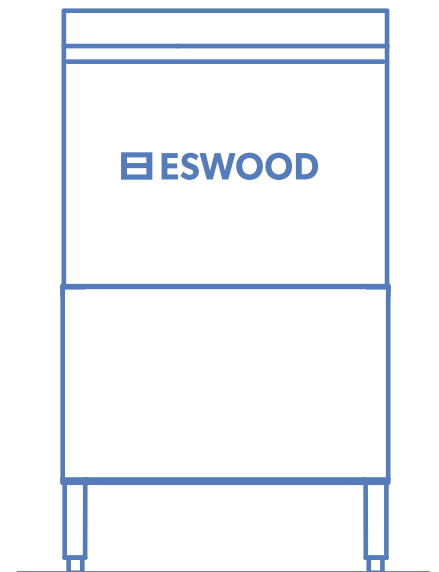



Up to 1800 glasses per hour

Selectable cold rinse

Easy to use controls

Durable stainless-steel body construction and wash arms

Accurate digital temperature controller and displays

Safety cut-off fitted to door

Easily removable spray arms and filters

Supplied with 430 x 360 (14" x 14") flat rack,
plate/saucer support and cutlery basket

- A. Drain 2" BSP gravity.
- B. Hot Water Supply 3/4" BSP x 1.5m braided hose
- C. Cold Water Supply 3/4" BSP x 1.5m braided hose
- D. Electrical connection - 2m 15A plug

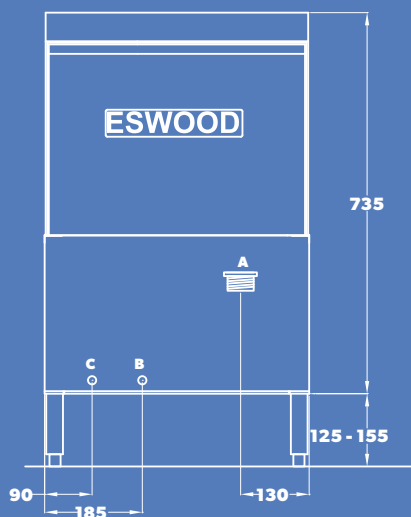
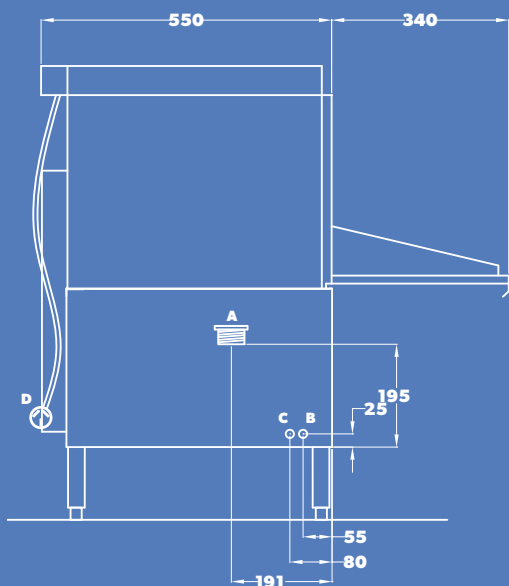

IW3N

Professional Undercounter Glasswasher

IW3N Specifications

DIMENSIONS (WxDxH)	510 x 550 x 875 mm
DEPTH WITH DOOR OPEN	890 mm
RACK SIZE – G74N (WxD)	430 x 360 or 400 x 400 mm
WEIGHT	40 kg
ELECTRIC CONNECTION	15A Single Phase
RATING	3.3 kW
WATER SUPPLY	65°C / 1-4 bar (15-58 psi)
PACKED	0.2 m ³
MEAL SERVICE	1800 glasses / hour
WASH CYCLE	25 sec Hot Cycle 45 sec Hot & Cold Cycle 120 sec
DETERGENT PUMP	Fitted
WATER CONSUMPTION	7L Hot Cycle 7L Hot & 3L Cold Cycle
TANK CAPACITY	10L
WATERMARK APPROVAL	WM-022833
HACCP APPROVAL	PE-388-GE-09

Dimensions may change without notice in accordance with product development and design



WA DEALER
PRACTICAL PRODUCTS PTY LTD

PH: 08 9302 1299
51 Paramount Dr Wangara WA 6065
sales@practicalproducts.com.au
www.practicalproducts.com.au