

specifications

BC180-P

SKOPE Centaur Horizontal Pizza Counter
Chiller: BC180-P-2RROS-E

Supplied with 9 pans (175w x 320d x 150h)

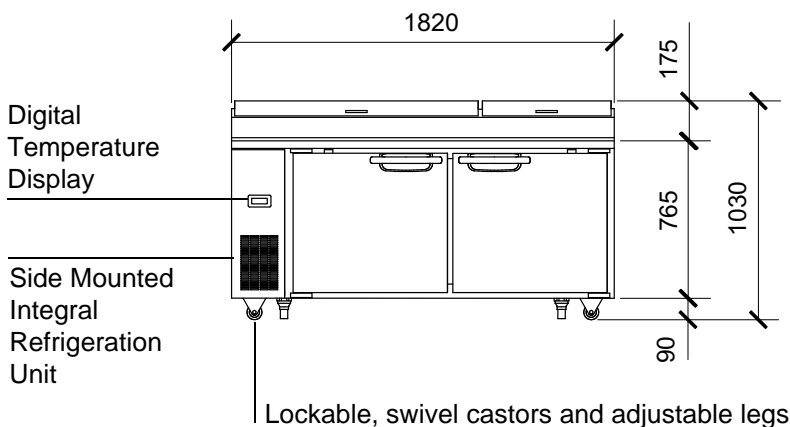
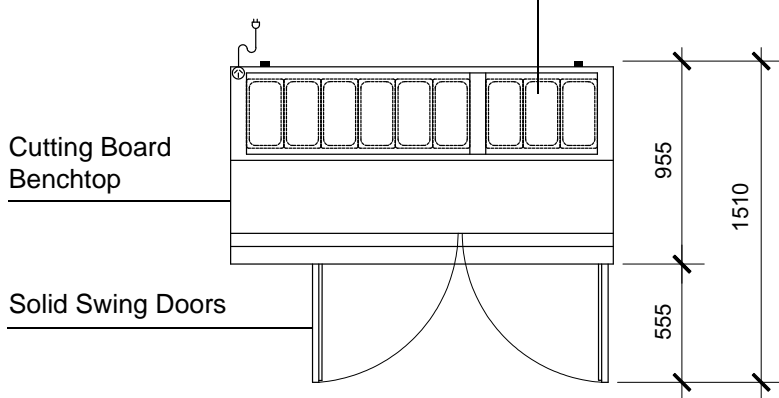

centaur

from SKOPE

CABINET DIMENSIONS

	External	Internal
Height:	1030mm	600mm
Width:	1820mm	1490mm
Depth:	955mm	680mm
Floor area:	1.74m ²	

WA DEALER
PRACTICAL PRODUCTS PTY LTD

PH: 08 9302 1299
51 Paramount Dr Wangara WA 6065
sales@practicalproducts.com.au
www.practicalproducts.com.au

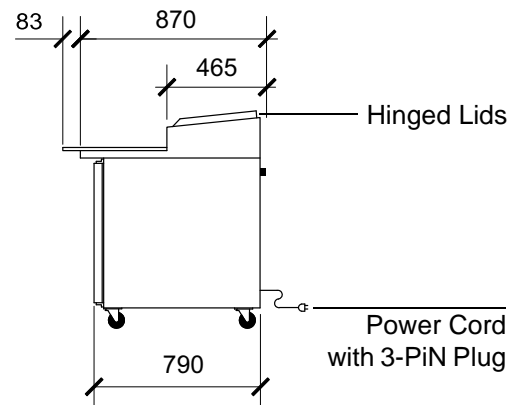

Copyright © 2008 SKOPE Industries Limited

CABINET SPECIFICATIONS

Refrigeration system:	Electronic controlled, side mounted integral refrigeration unit
Refrigerant:	R134a / 370g
Nominal capacity:	430 Watts
Cabinet internal volume:	597 litres
Insulation:	60mm thick, high density cyclo-isopentane polyurethane foam
Operating temperature:	0°C to +5°C up to 30°C ambient
Drainage:	No plumbing required
Electrical:	230-240 Volts a.c. 50 Hz, 2.90 Amps
Internal lighting:	n.a.
Power cord:	2.0m flexible power cord with 3-pin plug
Doors:	Solid, stainless steel self-closing doors - LH and RH hinged
Internal door opening size:	2 door openings: 580mm high x 670mm wide
Shelves:	Two adjustable shelves per door: 700mm wide x 500mm deep
Weight:	182 kg

SKOPE Industries Limited reserve the right to alter specifications without notice.

PSS0229 Rev. 2.0 March 2012

