

# UNDER COUNTER DRAWER

**FREEZER**

**MODEL : KUF12-3D-6**

OPTION  
2 Drawer Available



- Drawer pans not included.

## FEATURES / BENEFITS

### ■ STAINLESS STEEL CABINET CONSTRUCTION

The Turbo Air K series model boasts a stainless steel interior and exterior (galvanized steel back & bottom). It guarantees the utmost in cleanliness and long product life. The K series can add a touch of style to the most refined setting.

### ■ STURDY, CLEAN STAINLESS STEEL SHELVING

Shelves are the most important part of cleanliness as they come in direct contact with food. After a while, PVC coated wire shelves may peel, rust and lead to unsanitary conditions. Only the Turbo Air K series uniquely provides stainless steel shelving.

### ■ DURABLE STAINLESS STEEL DRAWERS

Drawers are easy to clean and assemble and each drawer can support up to weight of 60kg.

### ■ HOT GAS CONDENSATE SYSTEM

Through Turbo Air's creative innovation, the condensate system surfaces have been specially treated to resist corrosion. This not only increases efficiency without the risk of refrigerant leakage from corrosion, but also prevents the overflow of condensate water.

### ■ EFFICIENT REFRIGERATION SYSTEM

Turbo Air's solid door freezers are designed with oversized and balanced refrigeration systems. These include efficient evaporators and condensers for faster freezing and greater efficiency.

### ■ ERGONOMICALLY DESIGNED DOORS & DRAWERS

Customers' fatigue fades away with easy door grip and drawers that open effortlessly. These features along with self-closing doors make this the ultimate choice in customer convenience. ABS sheet door liners resist water condensation with thermal efficiency.

### ■ MAGNETIC DOOR GASKETS

Magnetic door gaskets are of one piece construction, removable without tools for ease of cleaning and replacement.

### ■ HIGH-DENSITY POLYURETHANE INSULATION

The entire cabinet structure and solid doors are foamed-in-place using high density, CFC free polyurethane insulation.

Model	Swing Door	Capacity (litres)	#of Shelves	HP	AMPS	Crated Weight (kg)	W x D x H (mm)
<b>KUF12-3D-6</b>	<b>0</b>	<b>311</b>	<b>0</b>	<b>1/3</b>	<b>3.3</b>	<b>106</b>	<b>1200 x 700 x 850</b>

# UNDER COUNTER DRAWER

**FREEZER**

**MODEL : KUF12-3D-6**

## Model : KUF12-3D-6

## PLAN VIEW

(unit : mm)

SPEC SHEET	KUF12-3D-6
Classification	Freezer
Cabinet dimension (WxDxH mm)	1200x700x850
Capacity (Liters)	311
Inner Temperature	-21°C ~ -12°C
Ambient Temperature	38°C
Doors	0
# of shelves	0
Refrigerant	R-134a
Compressor (HP)	1/3
Cooling Type	Fan cooling type
Insulation Type	Polyurethane/ Cyclopentane+CFC Free
Temperature Control Type	Digital
Amps (A)	3.3
Voltage (V/Hz/Ph)	240V 50Hz 1Ph
Power (W)	366
Weight (Kg)	106

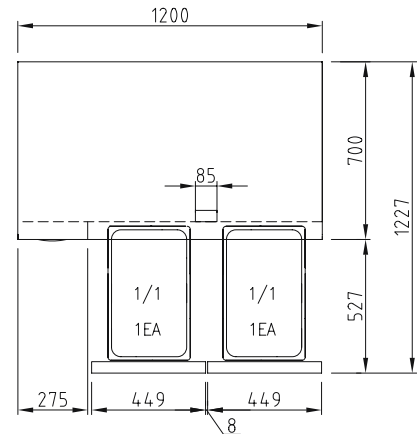

PLAN VIEW

Design and specifications subject to change without notice.  
Actual shipping weight may differ due to extra packing materials for product protection.

- DOOR LOCKS STANDARD
- INTERIOR LED LIGHTING STANDARD
- SELF-CONTAINED SYSTEM
- STANDARD 4" SWIVEL CASTERS WITH LOCKS ON THE FRONT SET
- TWO DRAWER TYPES AVAILABLE

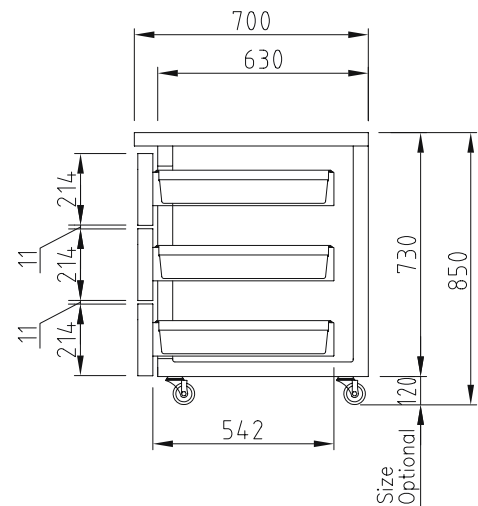

SIDE VIEW

**WARRANTY 2 YEARS**  
PARTS & LABOUR



PH: 08 9302 1299  
51 Paramount Dr Wangara WA 6065  
sales@practicalproducts.com.au  
www.practicalproducts.com.au

**Turbo air**