

metos
kitchen intelligence®

Metos Proveno 4G Combi Kettle

**Proveno is an Intelligent
and Simple Answer**



**for Easy and
Economic Food
Production**

METOS PROVENO 4G

**Metos Proveno is approachable and intuitive
...LOADED WITH SMART FUNCTIONS**

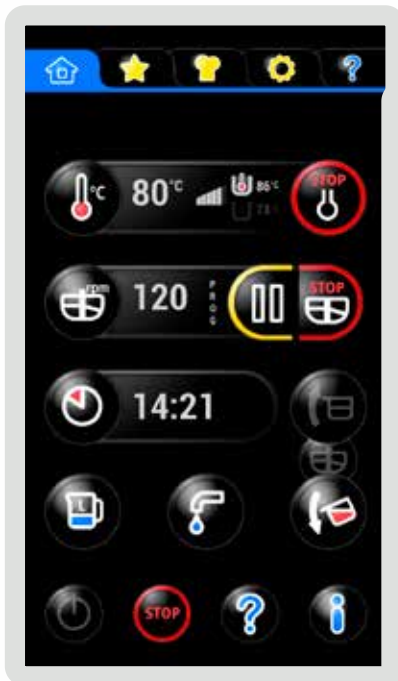

Guided touchscreen with clear symbols.

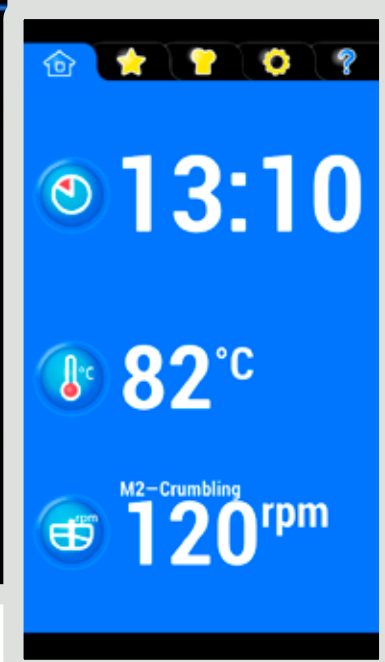

Various phases are displayed on the status display. Audible signals inform the user about any required actions.



Standard temperature and output settings.

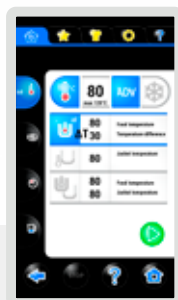

ADVANCED control according to exact temperature of both the food and the kettle jacket as well as the temperature difference of the two.

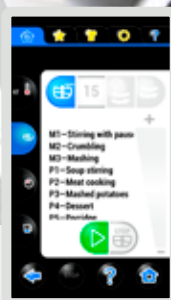

Ready-to-use mixing patterns for various types of mixing.

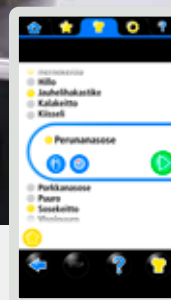

Ready-to-use programs for standard dishes. Recipe windows and audible prompting signals.

METOS PROVENO 4G



*Strong, maintenance-free, autoreverse mixer for all mixing and whipping. Also available as a heavy-duty version for extra heavy loads in sizes 150 and 200. *300-400 L kettles heavy-duty mixer is standard.*

Raised control panel is clearly visible, simple to use and protected from collisions.



All kettle sizes suitable for free standing installations.



Food water inlet directly positioned for flow into the kettle, even when tilting.



Distance to floor is over 600 mm when kettle is fully tilted. The high tilting kettle is fast and easy to empty. 600 mm high trolleys fit under the kettle pouring lip.



Reel-in handshower or other handshower models are optional.

Touchscreen enables easy programming

Programming is now a standard feature in Proveno 4G. An unlimited number of programmes with unlimited number of program phases may be saved and read. Easy programming via kettle's touchscreen. The kettle has various standard programs already installed which are easily edited and saved for your own use together with the necessary ingredient data. Additionally, it is easy to export kettle functions to programs. You can create favourite pages for programs and sort the pages according to subjects such as, for example, potato dishes.



Tips

Ready to use programs may be pre-set according to time and date, for example, for preparing porridge for Monday morning.



You can export all kettle functions to programs.

Pre-set starting of the programs according to time and date.

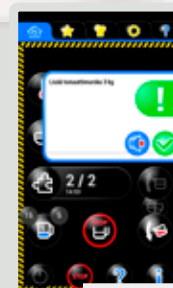
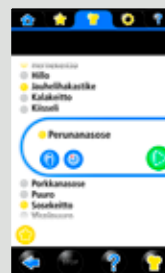
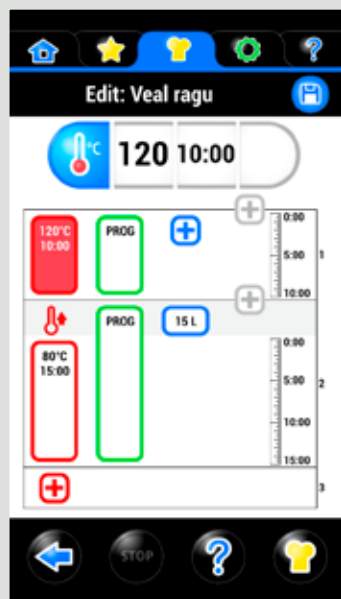

Ingredients may be listed in the recipe windows.

Favourite pages for saving the most popular programs according to, for example, the recipe's main ingredient.

METOS PROVENO 4G

Proveno free standing installations including groups, steam kettle groups, ice bank kettles

- Free standing kettles can be group installed
- Steam heated kettles can be group installed
- Ice bank connected kettles can be group installed
- Installation flanges prevent kettle from moving but not lifting away when needed
- Proveno 4G and Viking 4G kettles can be mixed in groups



Unique installation flanges
-no holes in the floor materials
-allow kettle lifting away if needed

All unique features!!

Space saving group installations
- even free standing kettle can be group installed saving space of another pillar
- Proveno 4G and Viking 4G kettles can be mixed in same groups
- no restrictions to kettle sizes, any size or order within the group



Also steam kettles and ice bank connected kettles can be installed in groups.

ProTemp temperature control is based on real-time temperature



The ProTemp advanced temperature control helps to prepare even the most demanding dishes and prevent food from burning. You can see the progress of the dish as well as the kettle jacket, cooking function helps to reduce loss and stringiest ingredients juicy by simmering for a long period of time.

The real-time temperature of the food and the mixer is constantly displayed while cooking. The temperatures are saved and downloadable for inhouse monitoring purposes.

Sous vide

Cooking in low temperature

Melting chocolate

Mixing and proving of dough

Cold production and desserts

Milk-based foods

Wireless temperature monitor Metos ioLiving for inhouse controlling

Metos ioLiving is a wireless, easy-to-use and quickly implemented temperature monitoring system which enables ensuring food safety and quality monitoring easily and efficiently. The Metos ioLiving sensors collect temperature data in real time, and transfers the data via Bluetooth to Android mobile phones or tablets. From the phone or tablet the data is further transferred to an online service supporting all browsers. Metos ioLiving enables you to monitor the circumstances at various measuring points and locations online wherever you are. Human errors are eliminated in entering data and employees become available for more productive tasks.



Metos ioLiving is a fully automatic monitoring system which enables monitoring and saving of information in professional kitchen environments.

- **Inexpensive, and easy to use**
- **No software installation**
- **Transfers data to mobile devices**
- **Supports all browsers**
- **Daily, weekly and monthly reports**
- **Alarms**

Automatic cooling by Proveno is better and quicker than ever

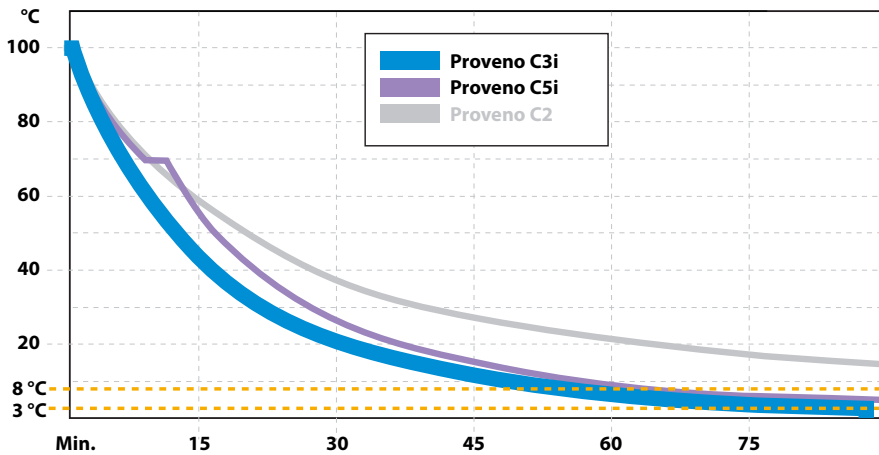

Automatic cooling: Set target food temperature and start – that’s it! Automatic steam jacket drainage after cooling. Food temperature continuously on display. Cooling can be interrupted, stopped or target temperature changed during cooling. Automatic stop when the product is not cooled down further, safety functions to avoid unintentional cooling. Cool & Hold function keeps the food at set temperature. Cooling media can be tap water or ice water from separate ice water supply.

Cooling with tap water*

Automatic cooling with tap water C2 – open circulation

Set target temperature and start – that’s it.

Cooling with ice bank*

Automatic ice water cooling C3i – closed circulation

Ice water circulates between the ice builder and the kettle’s steam jacket (closed circulation). Drainage with pressurised air saves water in ice water circulation.

Automatic two-phase cooling C5i

Cooling starts with tap water, when temperature difference is big and switches over to ice water cooling, when the difference has decreased. Ice water circulates between the ice builder and the kettle’s steam jacket.

* Kettle does not make water colder for cooling purposes. To achieve colder than tap water temperature kettle must be connected to an ice bank or fluid chiller.

METOS PROVENO 4G

Proveno's attention to details and accessories



The lid can be rotated in up position if needed for cleaning

All parts are dishwasher proof.



Unique stainless steel lid. All parts are easily removable and dishwasher proof. A safety grid lid comes as standard.

Room for utensils and accessories on top of the kettle stand. Enough room a GN 1/1 pan!

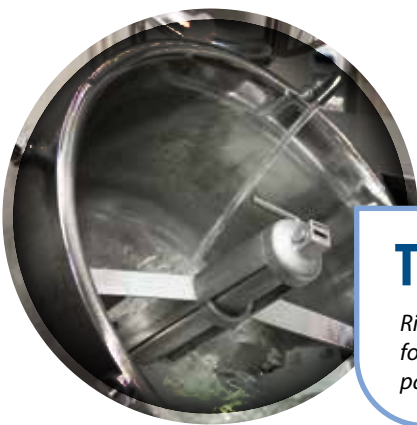

Tips

Rinse by tilting, for example pasta

Automatic filling with water: adjustable and by-pass to drain prior to filling up for "the first water" from the tap if you do not want to use it for cooking. Automatic filling up with water and manual filling up via push button (litres displayed) - works also when the kettle is being tilted.

Blender kit (option) and specialised handmixer

Handmixer fits firmly to a connection on a special lid and a special mixer tool mixes simultaneously. The lid and the mixer tool for use with handmixer are suitable for all Metos 40-100 L kettles.

Cream soups safely. Incredibly smooth purees with blender kit.



METOS PROVENO 4G

Proveno kettle is easy to clean



Glossy, polished surface is easy to clean with cleaning brush or cleaning tool.



Easily removable scrapers. All parts are machine washable.

ProTemp food temperature control prevents food from burning to surfaces. Even milk based food does not stick or scorch. Kettle cleaning is extremely easy.



The kettle washing tool is attached to the standard mixer.



All lid parts and mixer tool parts can be washed in dishwasher.

Tips

Always empty the kettle with the water pouring aid to keep the floor tidy and the floor drain unclogged. The water pouring aid is easy to clean, even in a dishwasher.



Ready-to-use washing program. Individual washing programs may be saved as necessary.

Tips

Use cooling when washing the kettle: 4 minutes cooling and the kettle is cool enough for washing.



Plenty of hand shower options.

Standard features

- Proveno 4G kettle with integrated mixer
- Stepless mixing speed in all sizes 15-140 rpm/min, autoreverse
- Elevated control pillar with guiding touch panel
- Audiovisual signals for user
- Multi functional timer
- Programming on screen, unlimited number of programs and program phases, favourite pages
- Programs for basic foods and wash programs
- Mixing patterns and saving of your own patterns
- ProTemp – real time temperature control, food and jacket temperature separately controlled. Intelligent power setting from gentle warming to full power. Allows for example low temperature cooking, sous vide, proving and tempering.
- Delta T cooking – temperature of jacket rises accordingly when food temperature rises, temperature difference is determined.
- User privilege levels
- Automatic measured water filling
- Electric tilting 40-150 L kettles, hydraulic tilting 200-400 L kettles
- Tilting while mixing function
- Auto tilt-back
- USB Port on control panel for program updates, program transfers and HACCP data saving
- Teacher status for training
- Phone app for training
- Diagnostics for maintenance
- On screen energy and water consumption measuring
- Steam jacket automatic fill
- Rotating lid in up position
- Measuring stick



Metos Proveno 4G 100 L free standing



Metos Proveno 4G FS 400 L free standing

Metos Proveno ELECTRIC	Code	Dimensions mm	Electric connection
Metos Proveno 4G40E	4224300	1047x706x900/1535*	400V 3N~ 12,5 kW 25A
Metos Proveno 4G 60E	4224302	1047x706x900/1535*	400V 3N~ 18,0 kW 32A
Metos Proveno 84G 0E	4224304	1154x750x900/1535*	400V 3N~ 22,0 kW 40A
Metos Proveno 4G 100E	4224306	1154x750x900/1535*	400V 3N~ 22,0 kW 40A
Metos Proveno 4G 150E	4224308	1360x969x900/1535*	400V 3N~ 27,6 kW 50A
Option extra power 150EH	4222992		400V 3N~ 35,6 kW 63A
Metos Proveno 4G 200E	4224310	1360x969x900/1535*	400V 3N~ 35,6 kW 63A
Option extra power 200EH	4222992		400V 3N~ 46,5 kW 80A
Metos Proveno 4G 300E	4224312	1560x1181x900/1535*	400V 3N~ 47,6 kW 80A
Option extra power 300EH	4222992		400V 3N~ 60,8 kW 100A
Metos Proveno 4G 400E	4224314	1560x1181x1050/1535*	400V 3N~ 62,0 kW 100A

Also steam heated models.

*control pillar/control panel



Free standing frame

Free standing frames available.

METOS PROVENO DIMENSIONS

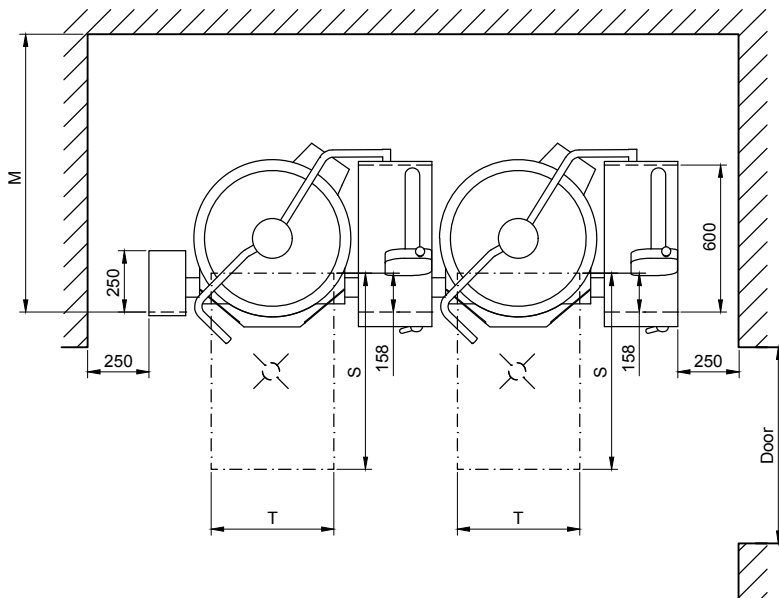
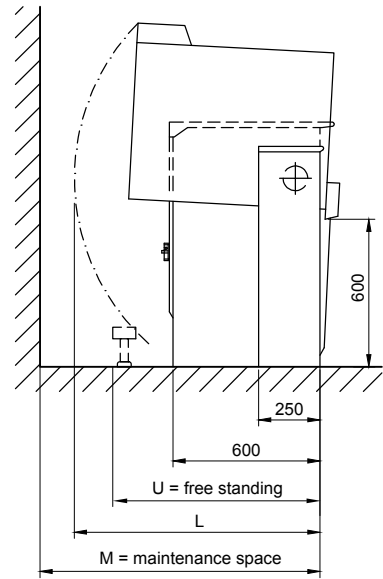
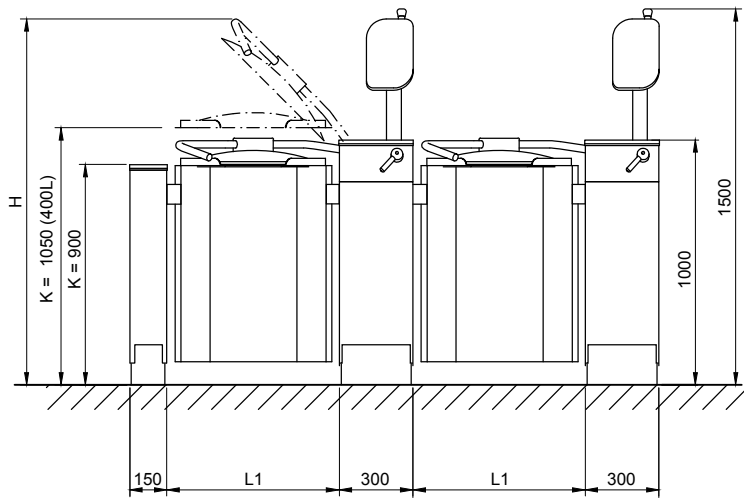

Proveno	L1 (mm)	H (mm)	K (mm)	L (mm)	M (mm)	S (mm)	T (mm)	U (mm)	Door (mm)	Weight (kg)
40	594	1740	900	870	1055	800	400	860	800	200
60	594	1740	900	955	1180	800	400	860	800	210
80	704	1745	900	1010	1235	800	500	890	800	230
100	704	1745	900	1010	1235	800	500	890	800	265
150	910	1945	900	1075	1170	800	600	1110	1000	305
200	910	1945	900	1155	1285	800	600	1110	1000	345
300	1110	2110	900	1280	1320	1000	600	1010	1200	415
400	1110	2080	1050	1280	1320	1200	600	1010	1200	475

National and local regulations must be observed when installing the kettle.

Installation

- Single kettle
- Kettle group

- Sub surface installation



- Surface installation



- Free standing



- Installation flanges



- Mid floor Kit1
- Mid floor Kit2



METOS PROVENO 4G

Installation frame kits

	Code
Surface installation frame	4224000
Sub-surface installation frame	4224002
Free standing installation 40-100L kettle	4224008
Free standing installation 150-400L kettle	4224010
Free standing, installation flanges	4224020
Free standing, mid floor kit 1	4224016
Free standing, mid floor kit 2	4224018
Group installation, surface	4224004
Group installation, sub-surface	4224006
Group installation, free standing 40-100L kettle	4224012
Group installation, free standing 150-400L kettle	4224014

Factory fitted options

	Code
Automatic tap water cooling (C2)	4222950
Ice water cooling, icewater connection (C3i)	4222952
Two phase cooling, icewater connection (C5i)	4222954
Ice water cooling, icewater connection, pressurised air drainage* (C3iPA)	4222956
Two phase cooling, icewater connection, pressurised air drainage* (C5iPA)	4222958
Double water connection	4212292
Welded and seamless bowl panels with closed cell polyurethane foam insulation	4224022
Standard Handshower S1	4222966
Heavy-duty Handshower S2	4222964
Reel-in Handshower S3	4222962
Wireless HACCP Transmitter IoLiving	4008006
Draw off tap D1-std	4211972
Draw off valve connection D2-B/AUS SMS63 TC (delivered plugged) 80-400L	4222135
Arc valve CIP D2 SMS63 TC/ SMS51 male end	4222747
Butterfly valve D2 SMS63 TC	4215858
Adapter for pump hose D2 SMS63 TC/ SMS51 male end	4222764
Foot switch for mixing when tilting	4222960
Heavy-duty mixer 150 L**	4215823
Heavy-duty mixer 200 L**	4215720
Extra power for kettles, see table on previous page	4222992
Socket outlet 230V behind control panel	4224026



Foot switch for mixing when tilting releases hands.



Socket outlet in control panel

*Drainage with pressurised air saves water in ice water circulation.
**300-400 litre kettles come with Heavy-duty mixer as standard.



Standard hand shower



Heavy-duty hand shower



Reel-in hand shower



Draw off tap D1-std



Draw off valve connection D2-B/AUS SMS63 TC (delivered plugged)



Arc valve CIP D2 SMS63 TC/ SMS51 male end



Butterfly valve D2 SMS63 TC



Adapter for pump hose D2 SMS63 TC/ SMS51 male end

METOS PROVENO 4G ASSEMBLY RECOMMENDATIONS



Cook-serve

- kettle
- cooling C2
- strainer plate
- +extension 300-400L
- whipping grid
- hand shower
- wash tool
- ioLiving HACCP sensor
- multipurpose trolley MPT-450
- blender kit



Hot-fill

- kettle
- draw off valve connection D2AUS
- arc valve
- cooling C2
- strainer plate
- +extension 300-400L
- whipping grid
- hand shower
- wash tool
- ioLiving HACCP sensor
- multipurpose trolley MPT-450
- accessory trolley AT-77
- blender kit
- long plug system



Sous vide

- kettle
- sous vide basket
- cooling C3i
- pressurised air drainage
- ice bank
- hand shower
- wash tool
- ioLiving HACCP sensor
- multipurpose trolley MPT-450
- hot fill bag support
- lift for sous vide basket



Cook-chill

- kettle
- cooling C3i
- pressurised air drainage
- ice bank
- strainer plate
- +extension 300-400L
- whipping grid
- hand shower
- wash tool
- ioLiving HACCP sensor
- multipurpose trolley MPT-450
- blender kit



Automatic dosing

- kettle
- draw off valve connection D2AUS
- arc valve
- long plug system
- short plug system
- dosing system DOS-1
- dosing system DOS-2
- accessory trolley AT-77



Cold production

- kettle
- draw off valve connection D2AUS
- arc valve
- cooling C3i
- pressurised air drainage
- ice bank
- cooled food water
- strainer plate
- +extension 300-400L
- whipping grid
- hand shower
- wash tool
- ioLiving HACCP sensor
- accessory trolley AT-77
- long plug system

METOS KETTLE ACCESSORIES

Accessories	Code
Strainer plate 40-60	4222196
Strainer plate 80-100	4222198
Strainer plate 150-200	4222200
Strainer plate 300-400	4222202
Strainer plate extension 300-400	4222204
Pouring adapter 150-200	4222206
Pouring adapter 300-400	4222208
Whipping grid 40-60	4211203
Whipping grid 80-100	4211193
Whipping grid 150-200	4211186
Whipping grid 300	4211179
Whipping grid 400	4215872



Strainer plate

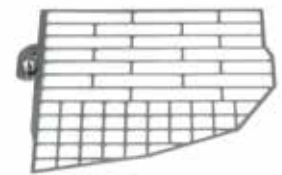

Whipping grid



Pouring adapter



Strainer plate extension for 300-400 litre kettles

Heavy-duty Mixing tool retrofit	Code
Heavy-duty Mixing tool 150 L	4215822
Heavy-duty Mixing tool 200 L	4215719
Heavy-duty Mixing tool 300 L	4215721
Heavy-duty Mixing tool 400 L	4215868

Kettle cleaning	Code
Cleaning tool 60 L	4222728
Cleaning tool 80 L	4222729
Cleaning tool 100 L	4222730
Cleaning tool 150 L	4222731
Cleaning tool 200 L	4222732
Cleaning tool 300 L	4222733
Cleaning tool 400 L	4222734
Cleaning brush	4222791
Scraper	4222790



Heavy-duty tool



Scraper

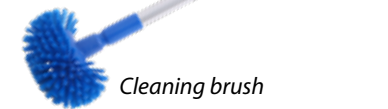

Cleaning brush

Accessories	Code
Potato stick Soft 670	4000031
Pouring support	4000012
Hot fill bag support	4222727

Sous Vide	Capacity	Code
Sous Vide Kit Proveno 80 L	35 kg	4222723
Sous Vide Kit Proveno 100 L	35 kg	4222724
Sous Vide Kit Proveno 150 L	60 kg	4222725
Sous Vide Kit Proveno 200 L	60 kg	4222726

Blender kit	Code
Blender kit for Proveno 40 L	4222735
Blender kit for Proveno 60 L	4222736
Blender kit for Proveno 80 L	4222737
Blender kit for Proveno 100 L	4222738

Includes blender lid, special mixing tool and blender MF2000 Combi

Trolleys	Code
Multipurpose trolley MPT-450, GN1/1	4554354
Mixer tool holder to MPT-450 trolley	4215990
Draining aid to MPT-450 trolley	4000009
Multipurpose trolley MPT-2/450, GN2/1	4554355
Kettle accessory trolley KTT	4554564
Kettle accessory trolley AT-77	4554586



Cleaning tool is attached to the mixing tool



Pouring support

Accessories	Code
Measurement stick 40	4222212
Measurement stick 60	4222214
Measurement stick 80	4222216
Measurement stick 100	4222218
Measurement stick 150	4222220
Measurement stick 200	4222222
Measurement stick 300	4222224
Measurement stick 400	4222226

METOS KETTLE ACCESSORIES



Potato stick



Measurement stick



Hot fill bag support



Sous Vide basket and Sous Vide tool



Blender top kit



Mixer tool holder for MPT-450 trolley



Multipurpose trolley MPT-450



Draining aid for MPT-450



Multipurpose trolley MPT-2/450



Kettle accessory trolley KTT



Kettle accessory trolley AT-77

WA DEALER
PRACTICAL PRODUCTS PTY LTD

PH: 08 9302 1299
51 Paramount Dr Wangara WA 6065
sales@practicalproducts.com.au
www.practicalproducts.com.au

