

## Viking 4G Steam Combi Jacketed Kettle

### Viking 4G COMBI 200S (4224230)

#### Standard Features

- Kettle with integrated mixer
- 200 litre capacity
- Steam heated version
- Elevated control pillar with selected features
- Mixing speed control 20-110 rpm/min, autoreverse
- Two mixing programs
- Electric tilting – tilting height 600mm
- Auto tilt-back
- Safety grid lid
- Measuring stick
- Retractable handshower
- Strainer plate
- Stainless steel construction
- Unit shown includes free standing floor kit - other options available

Please refer to Moffat price list for options and accessories

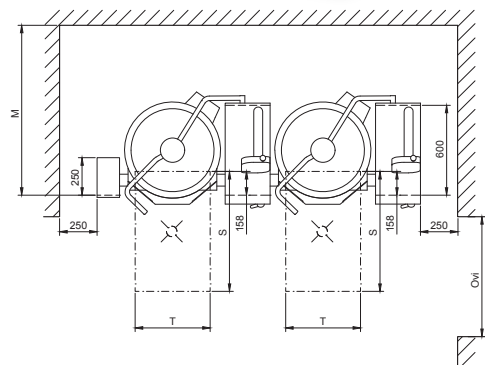
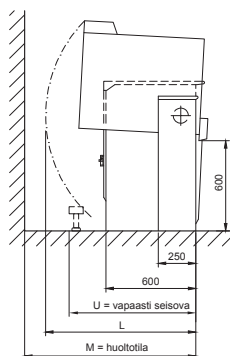
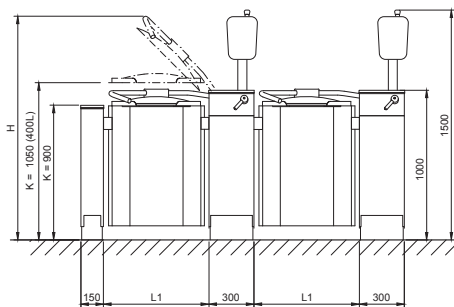

#### Technical Data

Net Volume 200 L  
Spare Volume 19 L  
Gross Volume 219 L

#### Dimensions

Width 1360mm  
Height 1500mm  
Depth 880mm

#### Connections

Water Cold ø15mm  
Hot ø10mm  
Steam R 1¼" 60 kg/hr  
Cond. Outlet R ¾"

Electrical Power 3.6 kW  
Voltage 400-415V,  
3P+N+E 50/60Hz  
AMP 16A

Total Heat 30 kW  
Load Latent 1.4 kW,  
Sensible 6.1 kW

Waste By kitchen  
contractor  
Nett Weight 340 kg

Model	L1 mm	H mm	L mm	M mm	U mm	T mm	Door mm
200S	910	1945	1075	1170	1110	600	1000



**WA DEALER**  
**PRACTICAL PRODUCTS PTY LTD**

PH: 08 9302 1299  
51 Paramount Dr Wangara WA 6065  
sales@practicalproducts.com.au  
www.practicalproducts.com.au