

Viking 4G Electric Combi Jacketed Kettle Viking 4G COMBI 80E (4224204)

Standard Features

- Kettle with integrated mixer
- 80 litre capacity
- Electric heated version
- Elevated control pillar with selected features
- Mixing speed control 20-110 rpm/min, autoreverse
- Two mixing programs
- Electric tilting – tilting height 600mm
- Auto tilt-back
- Safety grid lid
- Measuring stick
- Retractable handshower
- Strainer plate
- Stainless steel construction
- Unit shown includes free standing floor kit - other options available

Please refer to Moffat price list for options and accessories

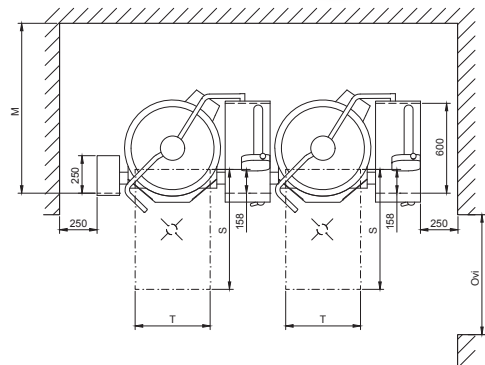
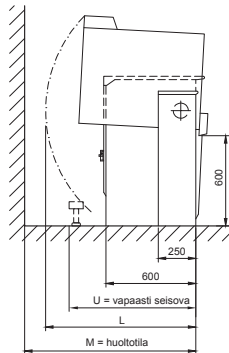
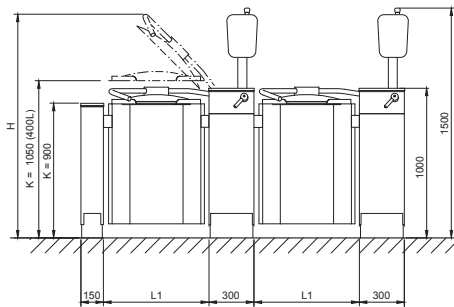

Technical Data

Net Volume 80 L
Spare Volume 11 L
Gross Volume 91 L

Dimensions

Width 1154mm
Height 1500mm
Depth 725mm

Connections

Water Cold ø15mm
Hot ø15mm

Electrical Power 14 kW
Voltage 400-415V,
3P+N+E 50/60Hz
AMP 32A

Total Heat 14 kW
Load Latent 0.8 kW,
Sensible 3.4 kW

Waste By kitchen
contractor
Nett Weight 225 kg

Model	L1 mm	H mm	L mm	M mm	U mm	T mm	Door mm
80E	704	1745	1010	1235	890	500	800

Australia
moffat.com.au
Moffat Pty Limited
740 Springvale Road
Mulgrave
Victoria 3170
Australia
Telephone +613-9518 3888
Facsimile +613-9518 3833
vsales@moffat.com.au

New Zealand
moffat.co.nz
Moffat Limited
45 Illinois Drive
Izone Business Hub
Rolleston 7675
New Zealand
Telephone +64 3-983 6600
Facsimile +64 3-983 6660
sales@moffat.co.nz



Disclaimer: All unit capacities are based on subjective testing. Moffat accepts no liability for production values. In line with policy to continually develop and improve its products, Moffat Limited reserves the right to change specifications and design without notice.

© Copyright Moffat Ltd
AN-MET-S-2001



PH: 08 9302 1299
51 Paramount Dr Wangara WA 6065
sales@practicalproducts.com.au
www.practicalproducts.com.au