

Viking 4G Electric Static Jacketed Kettle

Viking 4G 400E (4224114)

Standard Features

- 400 litre capacity
- Electric heated version
- Elevated control pillar with selected features
- Electromechanical controls
- Stepless temperature control
- Electric tilting – tilting height 600mm
- Auto tilt-back
- Measuring stick
- Retractable handshower
- Strainer plate
- Stainless steel construction
- Unit shown includes free standing floor kit - other options available

Please refer to Moffat price list for options and accessories

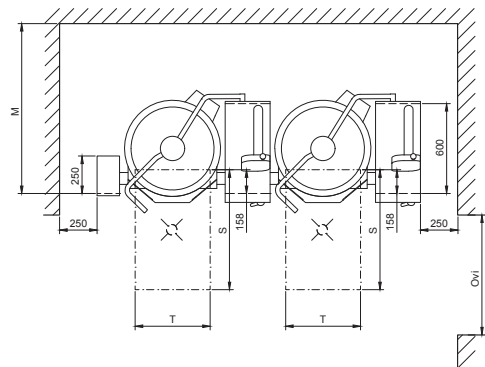
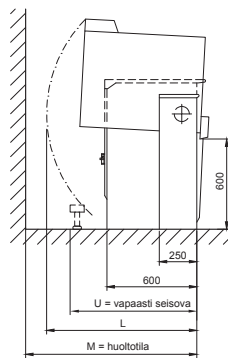
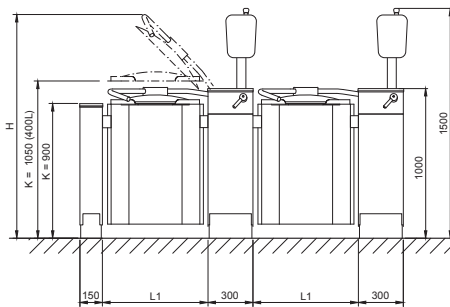

Technical Data

Net Volume 400 L
Spare Volume 33 L
Gross Volume 433 L

Dimensions

Width 1560mm
Height 1500mm
Depth 1073mm

Connections

Water Cold ø15mm
Hot ø10mm

Electrical Power 57.2 kW
Voltage 400-415V,
3P+N+E 50/60Hz
AMP 100A

Total Heat 57.2 kW
Load Latent 2.1 kW,
Sensible 11.5 kW

Waste By kitchen
contractor
Nett Weight 410 kg

Model	L1 mm	H mm	L mm	M mm	U mm	T mm	Door mm
400E	1110	2110	1280	1320	1010	600	1010



WA DEALER
PRACTICAL PRODUCTS PTY LTD

PH: 08 9302 1299
51 Paramount Dr Wangara WA 6065
sales@practicalproducts.com.au
www.practicalproducts.com.au