

Automatic rack-type dishwasher, capacity up to 150 racks, 2.700 plates or 5.400 glasses per hour



Product Advantages:

- Single rinse system - 260 l/h
- Stainless steel tank cover strainer system
- Optimum hygiene safety - deep drawn tank
- Two speed - 100 / 150 racks / hr
- Optional heat recovery for lower operating costs
- Stainless steel 1.5kW wash pump
- Including main switch and emergency stop
- Drop-In wash arms with no end caps
- Colour-coded cleaning assistance

Connections mirrorwise for R/L working direction

Machine shown with optional D-90-15 dryer.

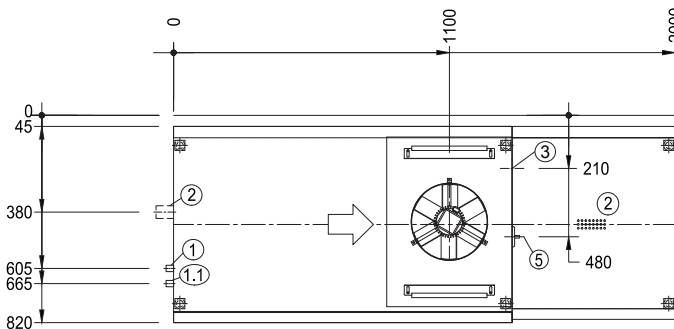
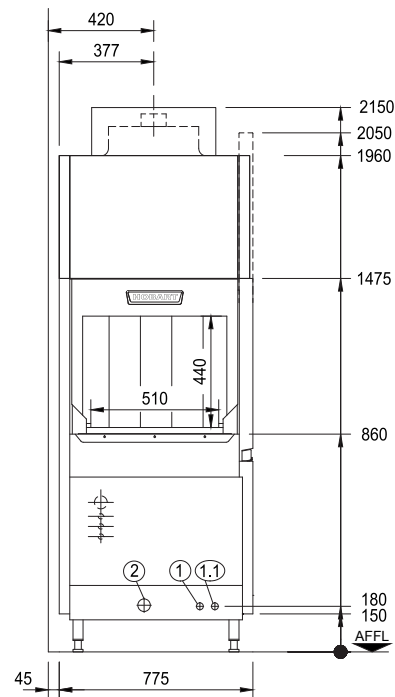
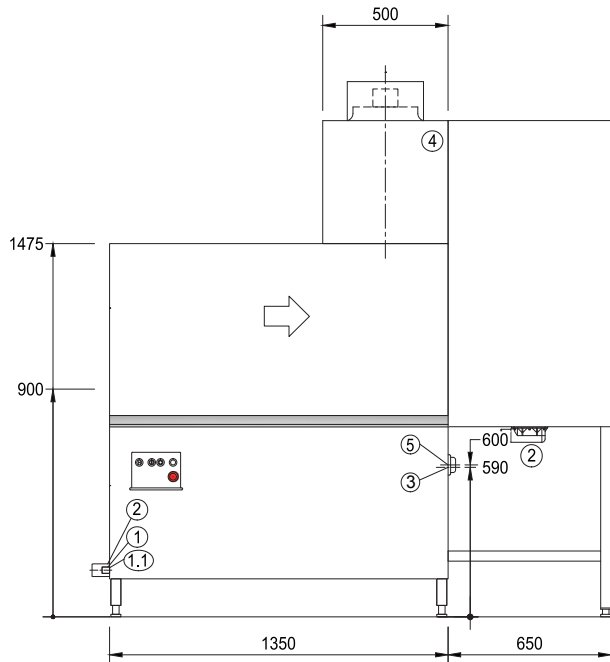

1	Warm water connection (filling)	R 3/4" 0 - 3°d, (1,4mmol/l); 55-65 degrees Celcius
1.1	For machine operation	Warm water connection for machine without heat recovery Cold water connection for machine with heat recovery
		R 3/4" 0 - 3°d, (1,4mmol/l); max. 260 l/h; demineralized water blended to have appr. 80 µs/cm
2	Drain	DN 50
3	Power supply	415/50/3 N+E Without dryer - 28.5kW / With dryer (D90) - 32.1kW
4	Exhaust	approx. 600m³/hr
5	Main switch	
		Table height 900mm Machine height +/- 25mm feet adjustable