

## ALTO SHAAM 750-TH/IIID

### LOW TEMPERATURE ELECTRONIC COOK & HOLD OVEN

Single compartment oven with either manual or electronic controls. (750-TH/111 features a digital control that includes 8 programmable menu buttons)

Oven is equipped with side racks with pan positions spaced on 35mm centers, 2 x stainless steel wire shelves, stainless steel drip pan with drain and external drip tray and casters.



**Please note:  
Supplied with glass door**

### STANDARD FEATURES

- HALO HEAT a controlled, uniform heat source that maintains close temperature tolerances throughout the cooking and holding function. Offers uniform and consistent cooking on a daily basis, low shrinkage of bulk or portion-cut protein items, higher food moisture content, and significantly longer holding life.
- Cooks, roasts, re-heats, and holds in the same cabinet with set-and-forget controls to provide a better distribution of work loads.
- Cooks by time or by probe to sense internal product temperature and automatically converts from cook mode to hold mode once the set parameters have been reached.
- Oven hoods, outside venting, and fire extinguisher systems are not required (IN MOST AREAS).
- Eight programmable menu buttons stores favorite recipes into memory (COOK/HOLD/TIME/PROBE SET-POINTS). Reduces operational requirements to simply loading the oven, pushing the power button, the preset menu button, and start.
- Clear, easy-to-read LED display indicates cook time remaining or the full range of programmed operating parameters.
- When cooking by probe, the oven maintains a record of the highest and lowest temperatures sensed by the food probe to assure foods are cooked to the temperature required.
- Oven includes the patented SureTemp™ heat recovery system to assure immediate compensation for any heat loss whenever the door is opened and provides an audible reminder if the door has been left open for more than three minutes.
- Antimicrobial handle retards the growth of illness-causing pathogens.

# ALTO SHAAM 750-TH-IIID

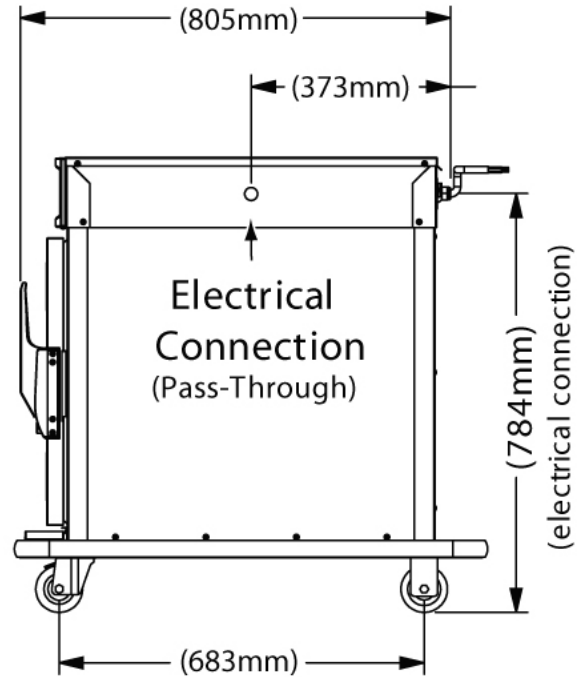
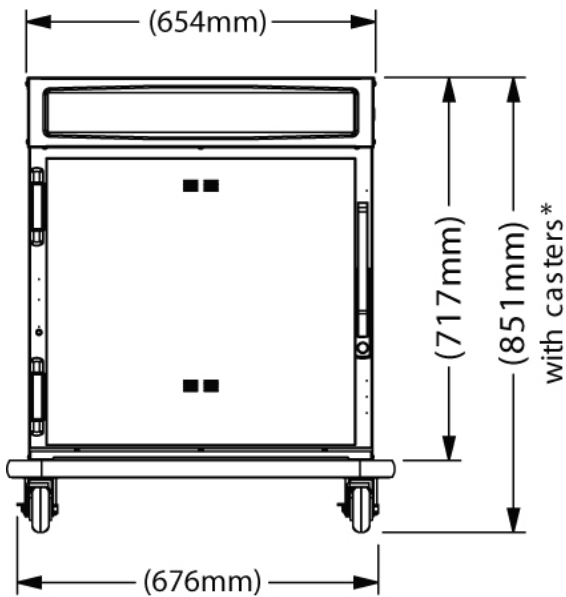

- \*(807mm) - with optional casters
- \*(894mm) - with optional casters
- \*(874mm) - with optional legs

## DIMENSIONS

External Dimension: 851H x 676W x 805D mm  
Internal Dimensions: 510H x 559W x 673D mm



WA DEALER  
PRACTICAL PRODUCTS PTY LTD

PH: 08 9302 1299  
51 Paramount Dr Wangara WA 6065  
sales@practicalproducts.com.au  
www.practicalproducts.com.au

## TECHNICAL DATA

Power Supply	15 amp single phase. 240 Volts
Voltage	240
Phase	1
Hertz	50
Amps	14.3
kW	3.3