

MODEL

Q70BR/G80

CODE

CR1014689

GAS BRATT PAN MANUAL TILTING 60 LT - STAINLESS STEEL TANK

QUEEN7

- 15/10 worktop thickness
- Stainless steel, Scotch-Brite finish
- Sturdy and powerful with compact design
- Depth of 700 mm means it will fit the most common configurations
- Catalogue offers more than 300 standard models
- Worktop, base cabinet and oven Versions
- Twin-piece knobs prevent the infiltration of dirt and are watertight
- Gas kitchens having burners with various configurations and power ratings: 3.5 kW - 5.7 kW - 7.0 Kw
- Wide range of accessories



Technical / functional characteristics

- Manual water fill.
- Self-balanced lid with double steel wall.
- Safety device interrupting power supply when tub is lifted.
- Adjustable temperature from 100 to 280°C.
- Stable flame burner.
- Electric ignition.
- Thermocouple safety valve.

DIMENSIONS	
Width (mm)	800
Depth (mm)	700
Height (mm)	900
Gas connection (∅)	1/2"
Electric connection (V/~ /Hz)	230V/1N 50 Hz
Cold water connection (∅)	3/4"
Hot water connection (∅)	

Cold soft water connection (∅)	
Drain (∅)	
Gas power (Mj/hr)	50
Electric power (kW)	0.2
Plate dimensions (mm)	
Tank capacity (L)	
Tank dimensions (mm)	
Internal oven dimensions (mm)	

MODEL

Q70BR/G80

CODE

CR1014689

SCHEMA DI INSTALLAZIONE - INSTALLATION DIAGRAM - INSTALLATIONSPLAN - SCHÉMA D'INSTALLATION - ESQUEMA DE INSTALACION -INSTALLATIESCHEMA - IINSTALLATIONSRTNINGAR

MISURE IN mm - DIMENSIONS IN mm - ABMESSUNGEN IN mm
MESURES EN mm - MEDIDAS EN mm - MATEN IN mm

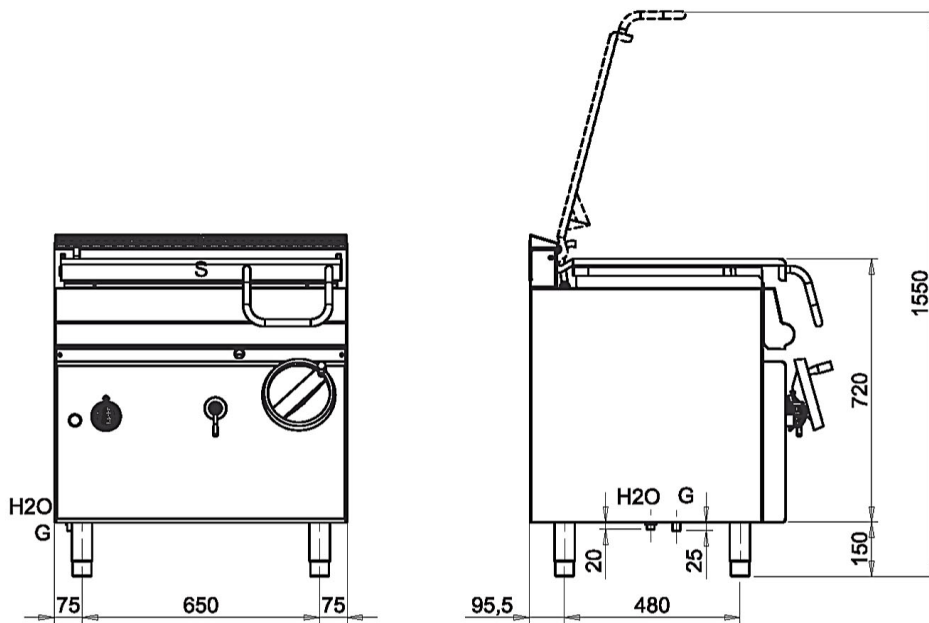

70BR/G8_

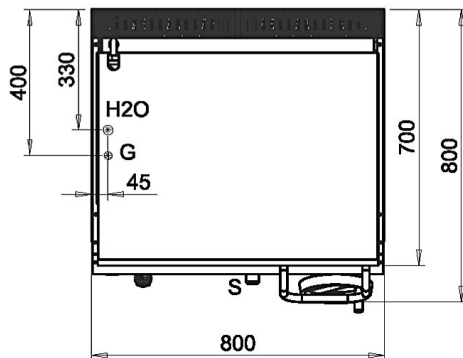

Legenda - Legende - Key - Légende - Leyenda - Legenda

- G** Attacco arrivo gas - Gasanschluss - Gas connection -Arrivée gaz - Union de gas - Gasaansluiting
EN 10226-1 R 1/2; EN ISO 228-1 G 1/2 (DK)
- H2O** Attacco arrivo acqua - Wasseranschluss - Water inlet - Arrivée eau - Union de agua - Wateraansluiting
EN ISO 228-1 G 3/4
- S** Scarico vasca - Wannenabflussrohr - Pan outlet - Vidange du bac - Descarga cuba - Water toevoer

WA DEALER
PRACTICAL PRODUCTS PTY LTD

PH: 08 9302 1299
51 Paramount Dr Wangara WA 6065
sales@practicalproducts.com.au
www.practicalproducts.com.au