

## Camcarriers®

### Front Loading

For GN Food Pans

Models UPC400, UPC400TR (Tamper Resistant)

#### Features & Benefits



- This large capacity Camcarrier easily handles storing and transporting food for any catering job, large or small, hot or cold foods.
- GN 1/1 Full Size Food Pan capacity:
  - 2 each 8" (20 cm) deep, 3 each 6" (15 cm) deep
  - 4 each 4" (10 cm) deep, or 6 each 2½" (6,5 cm) deep
- The insulated compartment will also hold multiple configurations of GN 1/2 and 1/3 size Food Pans.
- Store hot and cold foods in the same compartment with the use of the optional ThermoBarrier® Insulated Shelf Divider. Create a portable refrigerator by using the optional Camchiller®. No external power or ice required.
- Maintain hot food holding temperatures at higher levels and for longer when using two Camwarmers™ inside the compartment.
- Tough, one-piece seamless, double-wall, polyethylene construction is easy to maintain and won't dent, crack, rust, chip or break.
- Thick polyurethane foam insulated compartments and air tight gaskets help to retain food quality and temperatures without the use of external heat sources.
- Durable nylon door latches are easy to open and close securely to provide maximum temperature retention. Door swings open 270° to the side for easy loading and unloading
- Pop-up vent allows steam to be released and keeps menu items from becoming soggy.
- Ergonomic molded-in handles are located on top sides to provide safe and easy lifting and transporting.
- Available with Optional Tamper Resistant Security Package for correctional facility use. Ensures that hinge pins cannot be removed.
- Units interlock for easy stacking and transporting.
- Optional Camdolly® provides easy transport.
- Non-electrical.
- No assembly required.
- Available in 9 colors.



**UPC400**  
 (Shown with  
 CD400 Camdolly)



**UPC400**  
 (Shown with  
 Camwarmer)



Single latch opens and closes easily. Durable nylon construction.



Nylon hinge pins and hinge retainer clips allow you to easily remove and clean the door.

#### "UPC400 Keeps Food Hot for Hours!"

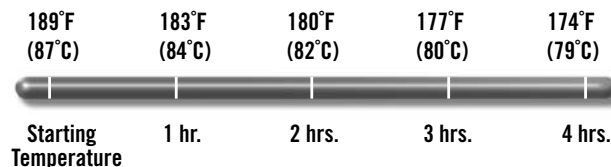

#### Approvals

# Camcarriers®

## Front Loading

For GN Food Pans

Models UPC400, UPC400TR (Tamper Resistant)

Item No. \_\_\_\_\_

Specifier Identification No. \_\_\_\_\_

Model No. \_\_\_\_\_

Quantity \_\_\_\_\_

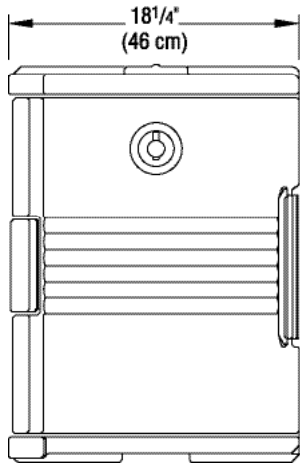

UPC400

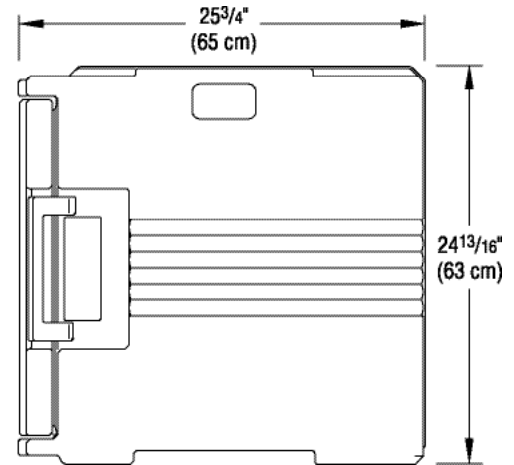

UPC400/UPC400TR

## Specifications

Dimension Tolerance: +/- 1/4" (0,64 cm)

Code	Description	Approx. Capacity	Exterior Dimensions W x D x H	Case lbs./cube Kg/m <sup>3</sup>
UPC400	Camcarrier	60 qts. (57 L)	18 1/4" x 25 3/4" x 24 13/16" (46 x 65 x 63 cm)	35 (7.19) 16 (0,2014)
<b>Tamper Resistant</b> UPC400TR	Camcarrier	60 qts. (57 L)	18 1/4" x 25 3/4" x 24 13/16" (46 x 65 x 63 cm)	35 (7.19) 16 (0,2014)

## Optional Accessories

- ThermoBarrier®  400DIV Gray (180)
- Camdolly®  CD400
- Strap  400STP
- Camchiller®  CP1220 Cold Blue (159)
- Camwarmer™  1210PW Granite Gray (191)

## Standard Colors

- Black (110)
- Navy Blue (186)
- Slate Blue (401)
- Cold Blue (159)
- Coffee Beige (157)
- Dark Brown (131)
- Granite Gray (191)
- Granite Green (192)
- Granite Sand (194)

## Architect Specs

The non-electrical food service and transport front loading carrier shall be a Camcarrier, Model UPC400... manufactured by Cambro Mfg. Co., Huntington Beach, CA 92647 U.S.A. It shall be made of one-piece, seamless, double-wall, high-density, polyethylene. It shall have an insulated polyurethane foam-injected compartment. It shall have 12 each molded-in rails on 1 1/2" (3,8 cm) centers. It shall accommodate a variety of GN Full, Half or Third Size Food Pans, from 2 1/2" (6,5 cm) to 8" (20 cm) deep. It shall have a nylon door latch and an airtight gasket and the compartment door shall swing open 270° to the side. It shall have a pop-up vent on the outside of the door. It shall have ergonomic molded-in handles located on each of the sides. It shall be available with an optional tamper resistant security package for correctional facility use. It shall require no assembly. It shall be available in 9 colors.



**WA DEALER**  
**PRACTICAL PRODUCTS PTY LTD**

PH: 08 9302 1299  
51 Paramount Dr Wangara WA 6065  
sales@practicalproducts.com.au  
www.practicalproducts.com.au