



# Electrolux



## Modular Cooking Range Line 700XP Two Wells Freestanding Electric Fryer 14 liter



Electrolux



Modular Cooking Range Line

700XP Two Wells Freestanding Electric Fryer 14 liter

<b>371085 (E7FREH2FF0)</b>	14+14-lt electric fryer free standing with 2 wells and 2 baskets, internal heating elements
<b>371144 (E7FREH2FFN)</b>	14+14-lt electric fryer free standing with 2 wells and 2 baskets, internal heating elements

### Short Form Specification

#### Item No.

To be installed on height adjustable feet in stainless steel. High efficiency tilting incoloy armoured heating elements (17.4kW) placed inside the wells. Deep drawn wells. Oil drains through a tap into a container under the well. Exterior panels in stainless steel with Scotch Brite finish. One piece pressed work top in 1.5 mm thick stainless steel. Right-angled side edges to allow flush-fitting junction between units.

### Main Features

- Unit to be mounted on height adjustable feet in stainless steel.
- High efficiency tilting heating elements attached inside the wells.
- Thermostatic regulation of oil temperature up to a maximum of 185 °C.
- Overheat protection thermostat as standard on all units.
- Oil drains through a tap into a drainage container positioned under the well.
- All major compartments located in front of unit for ease of maintenance.
- IPX 4 water protection.

### Construction

- Interior of well with rounded corners for ease of cleaning.
- All exterior panels in Stainless Steel with Scotch Brite finishing.
- One piece pressed 1.5 mm work top in Stainless steel.
- Model has right-angled side edges to allow flush fitting joints between units, eliminating gaps and possible dirt traps.

### Included Accessories

- 2 of Door for open base cupboard PNC 206350
- 2 of Full size basket for 14 and 15lt free standing fryers PNC 921691

### Optional Accessories

- Kit 4 wheels - 2 swivelling with brake - it is mandatory to install base support and wheels PNC 206135
- Flanged feet kit PNC 206136
- Frontal kicking strip for concrete installation, 200mm PNC 206146
- Frontal kicking strip for concrete installation, 400mm PNC 206147
- Frontal kicking strip for concrete installation, 800mm PNC 206148
- Frontal kicking strip for concrete installation, 1000mm PNC 206150
- Frontal kicking strip for concrete installation, 1200mm PNC 206151
- Frontal kicking strip for concrete installation, 1600mm PNC 206152
- Frontal kicking strip, 200mm (not for refr-freezer base) PNC 206174
- Frontal kicking strip, 400mm (not for refr-freezer base) PNC 206175
- Frontal kicking strip, 800mm (not for refr-freezer base) PNC 206176

APPROVAL: \_\_\_\_\_

700XP Two Wells Freestanding Electric Fryer 14 liter  
Modular Cooking Range Line

- Frontal kicking strip, 1000mm (not for refr-freezer base)  PNC 206177
- Frontal kicking strip, 1200mm (not for refr-freezer base)  PNC 206178
- Frontal kicking strip, 1600mm (not for refr-freezer base)  PNC 206179
- Kit 4 feet for concrete installation (not for 900 line free standing grill)  PNC 206210
- Pair of side kicking strips  PNC 206249
- Pair of side kicking strips for concrete installation  PNC 206265
- Oil drain pipe for 15lt free standing fryer  PNC 206301
- Chimney upstand, 800mm  PNC 206304
- Right and left side handrails  PNC 206307
- Door for open base cupboard  PNC 206350
- Base support for feet or wheels - 400mm (700/900)  PNC 206366
- Base support for feet or wheels - 800mm (700/900)  PNC 206367
- Base support for feet or wheels - 1200mm (700/900)  PNC 206368
- Base support for feet or wheels - 1600mm (700/900)  PNC 206369
- Base support for feet or wheels - 2000mm (700/900)  PNC 206370
- Rear paneling - 800mm (700/900)  PNC 206374
- Rear paneling - 1000mm (700/900)  PNC 206375
- Rear paneling - 1200mm (700/900)  PNC 206376
- Chimney grid net, 400mm (700XP/900)  PNC 206400
- 2 side covering panels for free standing appliances  PNC 216000
- Frontal handrail, 800mm  PNC 216047
- Frontal handrail, 1200mm  PNC 216049
- Frontal handrail, 1600mm  PNC 216050
- Large handrail - portioning shelf, 400mm  PNC 216185
- Large handrail - portioning shelf, 800mm  PNC 216186
- Full size basket for 14 and 15lt free standing fryers  PNC 921691
- 2 half size baskets for 12, 14 and 15lt fryers  PNC 921692
- Filter for fryer oil collection basin for 7lt, 14lt, 15lt free standing fryers  PNC 921693

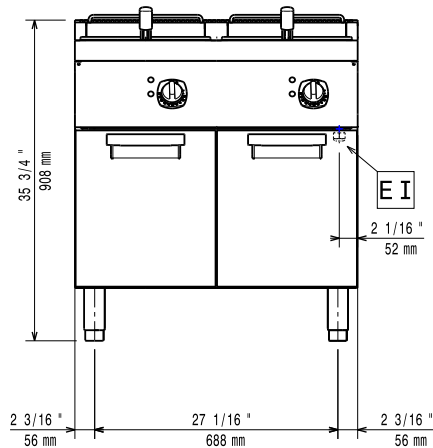
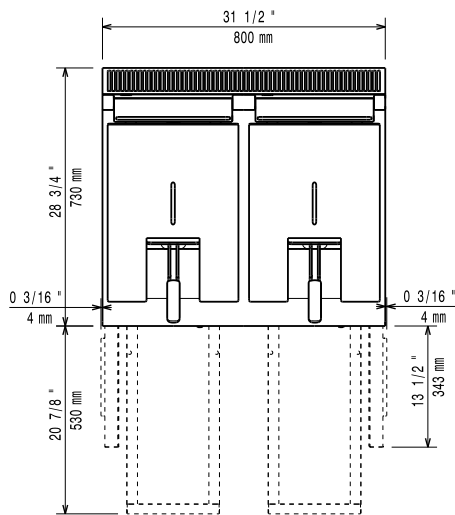
**Front**

**Top**

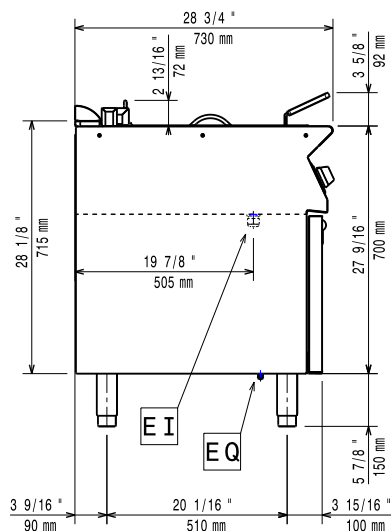
**EI = Electrical connection**  
**EQ = Equipotential screw**

**Side**

## Electric

### Supply voltage:

<b>371085 (E7FREH2FF0)</b>	400 V/3N ph/50/60 Hz
<b>371144 (E7FREH2FFN)</b>	230 V/3 ph/50/60 Hz

### Total Watts:

17.4 kW

## Key Information:

**Usable well dimensions (width):**

240 mm

**Usable well dimensions (height):**

285 mm

**Usable well dimensions (depth):**

380 mm

**Well capacity:**

12 lt MIN; 14 lt MAX

**Thermostat Range:**

105 °C MIN; 185 °C MAX

**Net weight:**

81 kg

**Shipping weight:**

<b>371085 (E7FREH2FF0)</b>	90 kg
<b>371144 (E7FREH2FFN)</b>	101 kg

**Shipping height:**

1140 mm

**Shipping width:**

820 mm

**Shipping depth:**

860 mm

**Shipping volume:**

0.8 m<sup>3</sup>

If appliance is set up or next to or against temperature sensitive furniture or similar, a safety gap of approximately 150 mm should be maintained or some form of heat insulation fitted.



**WA DEALER**  
**PRACTICAL PRODUCTS PTY LTD**

PH: 08 9302 1299  
51 Paramount Dr Wangara WA 6065  
sales@practicalproducts.com.au  
www.practicalproducts.com.au