



INLINE

4000 SERIES 1200 FREESTANDING/SQUARE HEATED

RANGE	INLINE 4000 SERIES	
TEMPERATURE	HEATED	
MODEL	IN-4H12-SQ-FF-FS	IN-4H12-SQ-SD-FS
FRONT	SQUARE/ FIXED FRONT	SQUARE/ SLIDING DOORS
INSTALLATION	FREESTANDING	
HEIGHT	1405mm	
WIDTH	1203mm	
DEPTH	778mm	

TEMPERATURE RANGE	+30°C – +90°C
RECOMMENDED CORE PRODUCT TEMPERATURE	> +65°C
ENVIRONMENTAL TEST CONDITIONS	22°C / 65% RH



Showing : Inline 4000 Series heated 1200mm square freestanding with fixed front

FEATURES

- High energy efficiency: 1.66 kWh per hour (average)
- Cabinet operating temperature range +30°C - +90°C
Recommended core product temperature >+65°C
- Smart display with toughened safety glass encased in brushed stainless steel frame

Fixed Front or Sliding Doors Heated Display

- Three tiltable, height-adjustable stainless steel wire rack shelves are full cabinet width to support maximum display capacity
- 25,000 hour LED lighting system at 2758 lumens per metre in cabinet top and shelves
- Unique shelf mounted ticket strip front and rear: 30mm
- Integrated ambient rear storage area

Operational Excellence

- Sliding doors (staff side) and fixed front or sliding doors options (customer side)
- Constructed from stainless and mild steel with toughened safety glass and double-glazed end panels for maximum energy efficiency, climate control and durability
- Low-wattage, high-density element provides even temperature distribution
- Fitted with adjustable 150mm legs (+30mm adjustment)

OPTIONS & ACCESSORIES

- Shelf trays: Toughened safety glass, stainless or mild steel. Colour and woodprint options available for steel shelf trays
- Stainless steel product trays with sides to contain product residue
- Stainless steel pie chutes and dividers
- Additional shelf
- Branded decals/inserts
- Rear door or end glass mirror application
- Adjustable 100mm legs (+25mm adjustment), lockable castors or unidirectional rollers
- Forward-facing controls
- Chassis configured for joinery installation
- Rear deck assemblies
- Thermal divider panels
- Custom joinery solution



Please contact FPG to discuss your requirements for meeting country-specific standards.



INLINE

4000 SERIES 1200 FREESTANDING/SQUARE HEATED

HEATED DATA

MODEL	TEMPERATURE RANGE	RECOMMENDED CORE PRODUCT TEMPERATURE	ENVIRONMENTAL TEST CONDITIONS	HEATING
IN-4H12-SQ-XX-FS	+30°C - +90°C	> +65°C	22°C / 65% RH	Low-wattage, high-density element

ELECTRICAL DATA

MODEL	VOLTAGE	PHASE	CURRENT	E24H (kWh)	kWh per hour (average)	IP RATING	MAINS		LED LIGHTING		
							CONNECTION	CONNECTION PLUG ¹	HOURS	LUMENS per metre	COLOUR
IN-4H12-SQ-XX-FS	220-240 V	Single	7.2 A	39.8	1.66	IP 20	3 metre, 3 core cable	10 amp, 3 pin plug	25,000	2758 per metre	Natural

¹Please advise country to change plug specification.

CAPACITY, ACCESS & CONSTRUCTION

MODEL	DISPLAY AREA	LEVELS	ACCESS FRONT	ACCESS REAR	CHASSIS CONSTRUCTION
IN-4H12-SQ-FF-FS	1.5 m ²	3 Shelves	Fixed front	Sliding doors	Stainless 304 and mild steel
IN-4H12-SQ-SD-FS	1.5 m ²	3 Shelves	Sliding doors	Sliding doors	Stainless 304 and mild steel

DIMENSIONS

MODEL	H x W x D mm (Uncrated)	MASS (Uncrated)
IN-4H12-SQ-XX-FS	1405 x 1203 x 778	170 kg

Crated weights and dimensions vary. Please contact us for information on your shipment.

Installation note:

Model cutout dimensions: IN-4H12-SQ-XX-FS models require 1172 x 746mm benchtop cutout. Joinery height 560mm (see product manual for installation guide).

Please contact FPG to configure this freestanding cabinet for joinery installation option.

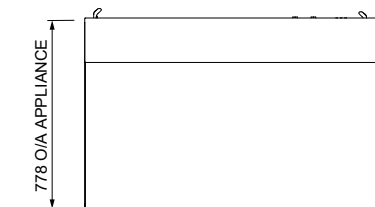

PLAN VIEW

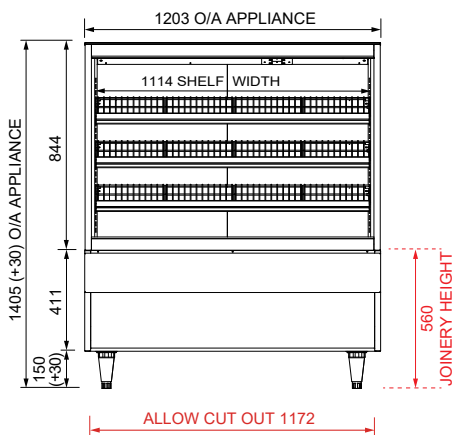

FRONT ELEVATION

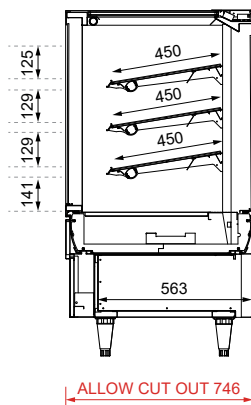

SECTION VIEW

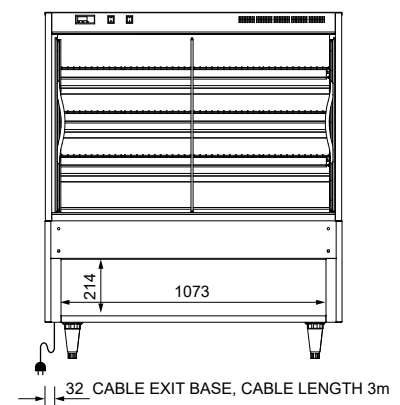

REAR ELEVATION

More information including technical data and installation guidelines is available from the Product Manual published on our website.

In line with our policy to continually develop, improve and support our products, Future Products Group Ltd reserves the right to change specifications and design without notice.