



# visair

## UPRIGHT 2400 OPEN FRONT HEATED WITH 3 SHELVES

MODEL	IN-VH24-A002
RANGE	VISAIR UPRIGHT
INSTALLATION	FREESTANDING/ROLLERS
FRONT	OPEN FRONT
TEMPERATURE	HEATED
HEIGHT	1480mm
WIDTH	2454mm
DEPTH	736mm

TEMPERATURE RANGE	+30°C - +85°C
RECOMMENDED CORE PRODUCT TEMPERATURE	> 65°C
ENVIRONMENTAL TEST CONDITIONS	22°C / 65% RH



## FEATURES

**High energy efficiency: 4.6 kWh per hour (average)**

**Consistently maintains hot product >+65°C**

- Smart steel frame powdercoated black with black trim and fittings. Internal cabinet rear is brushed stainless steel

### Open Front Heated Display

- 4 full-width display levels: 3 fixed **IWave** quartz infrared shelves and heated base
- Each **IWave** shelf is brushed stainless steel and fitted with x4 575mm width removable aluminium drip trays, ticketing insert 30mm (height), and Hot warning adhesives
- Pluggable 25,000 hour LED lighting at the cabinet top and each shelf

### Operational Excellence

- FPG **IWave** heating technology uses low wattage quartz infrared elements complemented with a heating coil in the base for even temperature distribution and extended shelf life
- Fitted with an electronic controller for energy efficiency
- Safer for consumers - display surfaces are maintained < +65°C and the internal air temperature is lower than in many fan-assisted cabinets
- No noise pollution - this cabinet runs silently
- Constructed from mild and stainless steel. Fully double-glazed glass for maximum energy efficiency, temperature control and durability
- Fitted with protective black buffer rail at base front and sides
- Fitted with unidirectional rollers and stabilisers



IWave

Showing : Visair Upright heated 2400mm open front cabinet with 3 IWave shelves

## OPTIONS & ACCESSORIES

- Drip tray 1155mm width
- Castors
- Custom colour or branded decals





# visair

## UPRIGHT 2400 OPEN FRONT HEATED WITH 3 SHELVES

### HEATED DATA

MODEL	TEMPERATURE RANGE	RECOMMENDED CORE PRODUCT TEMPERATURE	ENVIRONMENTAL TEST CONDITIONS	IWAVE HEATING
IN-VH24-A002	+30°C - +85°C	> +65°C	22°C / 65% RH	Low wattage infrared quartz elements

### ELECTRICAL DATA

MODEL	VOLTAGE	PHASE	CURRENT	E24H (kWh)	kWh per hour (average)	IP RATING	MAINS		LED LIGHTING		
							CONNECTION	CONNECTION PLUG	HOURS	LUMENS	COLOUR
IN-VH24-A002	220-240 V	Single	29.7 A	110.4	4.6	IP 22	Fixed wiring <sup>1</sup>	N/A	25,000	2758 per metre	Natural

<sup>1</sup>Please see the manual for more information.

### CAPACITY, ACCESS & CONSTRUCTION

MODEL	DISPLAY AREA	LEVELS	ACCESS FRONT	ACCESS REAR	CHASSIS CONSTRUCTION
IN-VH24-A002	3.8 m <sup>2</sup>	3 Shelves + Base	Open front	Fixed	Mild & stainless steel

### DIMENSIONS

MODEL	H x W x D mm (Uncrated)	MASS (Uncrated)
IN-VH24-A002	1480 x 2454 x 736	410 kg

Crated weights and dimensions vary. Please contact us for information on your shipment.

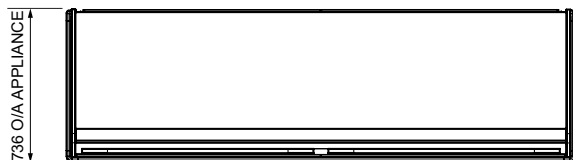

PLAN VIEW

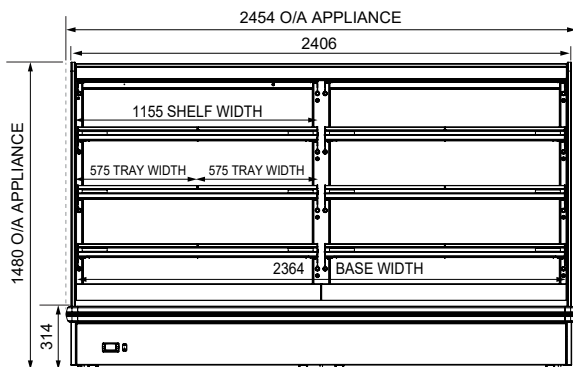

FRONT ELEVATION

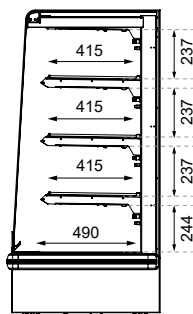

SECTION VIEW

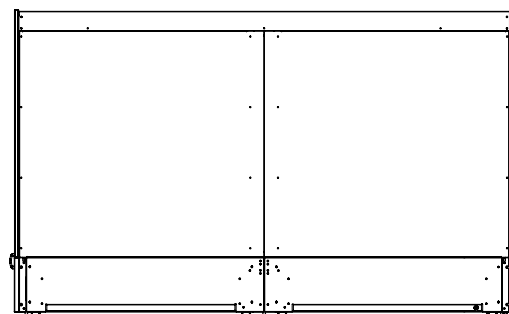

REAR ELEVATION

More information including technical data and installation guidelines is available from the Product Manual published on our website.

In line with our policy to continually develop, improve and support our products, Future Products Group Ltd reserves the right to change specifications and design without notice.



PH: 08 9302 1299  
51 Paramount Dr Wangara WA 6065  
sales@practicalproducts.com.au  
www.practicalproducts.com.au