



Main Features

- Advanced visual control panel offers complete customization and versatility of all baking parameters including auto-pilot start up mode, exhaust discharge adjustments, 9 baking programs & top and bottom heating control
- Quickly reaches working temperature of 300°C in less than 30 minutes and 420° in less than 45 minutes
- Double glazed glass door along with sealing fiber chamber gaskets & glass fiber insulation prevents burn, reduces any heat loss and allows the user to bake with the door open
- Economy mode forces the ceiling and floor resistors to switch on limiting the required power by 50%
- Fully constructed in high grade (AISI) 304 stainless steel
- Well lit interior chamber light
- No Gap Refractory Stone ensures no difficult-to-clean spots where flour and cheese can get stuck, burn and ruin the taste of the pizza
- Modular so can be stacked up to 3 units high



IWOS™ Italian Wood SYSTEM Oven Substitute

KING is the only oven in the world baking with the innovative IWOS™ System (Italian Wood Oven Substitute) which mechanically replicates the air circulation found within a wood-burning pizza oven.

SPECIFICATIONS

Voltage	400 Volt AC 3/N/PE
	230 Volt AC 1/N/PE
Power	10,4 kW
Weight	192 kg
Plug Supplied	NO
Capacity	6 x 34cm pizza
Thermostat	60-500°C
Warranty	4 Year Warranty (2 yr Labour 4 yr Parts)

DIMENSIONS

External Width	1485mm	Internal Width	1050mm
External Depth	1140mm	Internal Depth	700mm
External Height	425mm	Internal Height	155mm

ACCESSORIES

Single Deck Stand	AFOPIEDAZ6NR1M
Double Deck Stand	AFOPIEDAZ6NR2M
Triple Deck Stand	AFOPIEDAZ6NR3M
Extractor Hood	AFOCAPKING6G
Double Door Proofer Insert	AFOCELUN

KING 6G

FOR KING6GTR400

FRONT

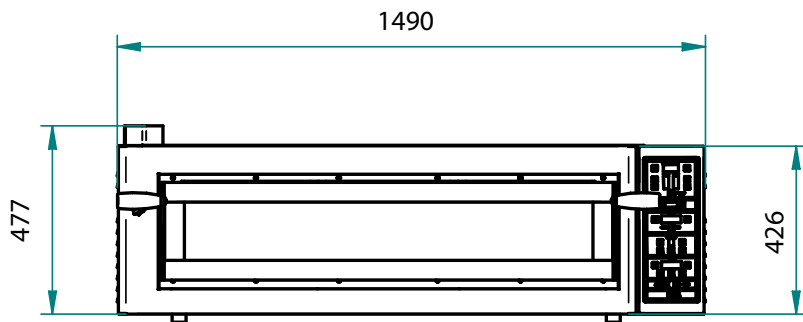

SIDE

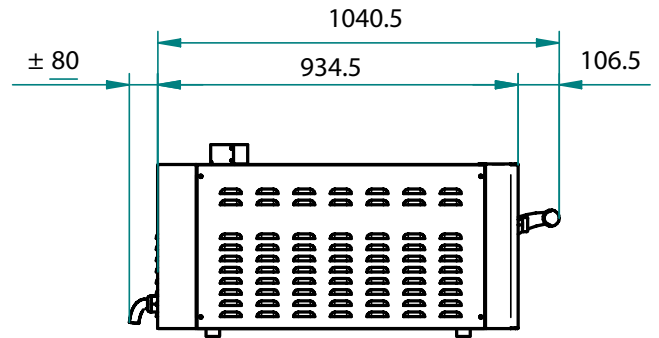

TOP

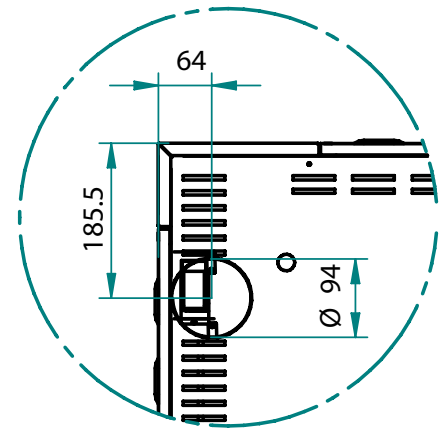
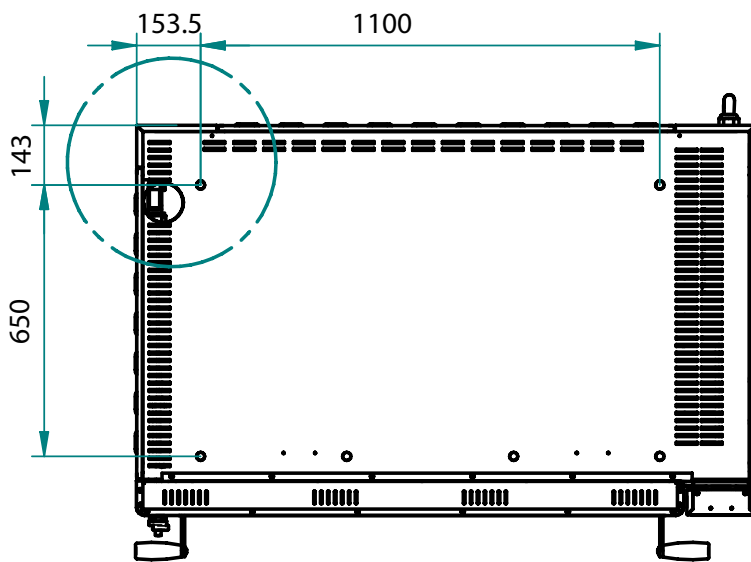

We reserve the right to alter specifications without notice.

KING 6G - EXTRACTOR HOOD

FOR KING6GTR400

AFOCAPKING6G

FRONT

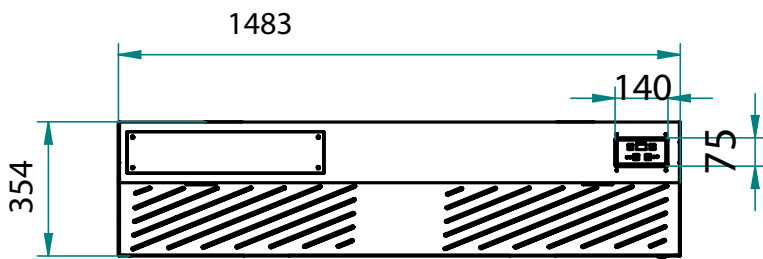

SIDE

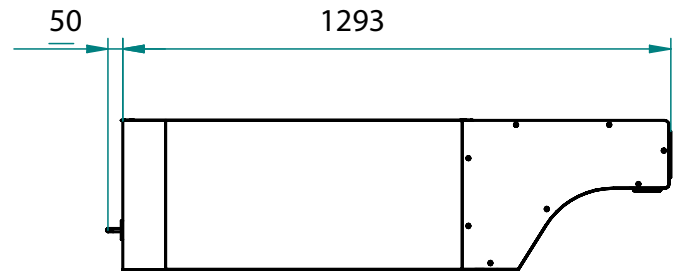

TOP

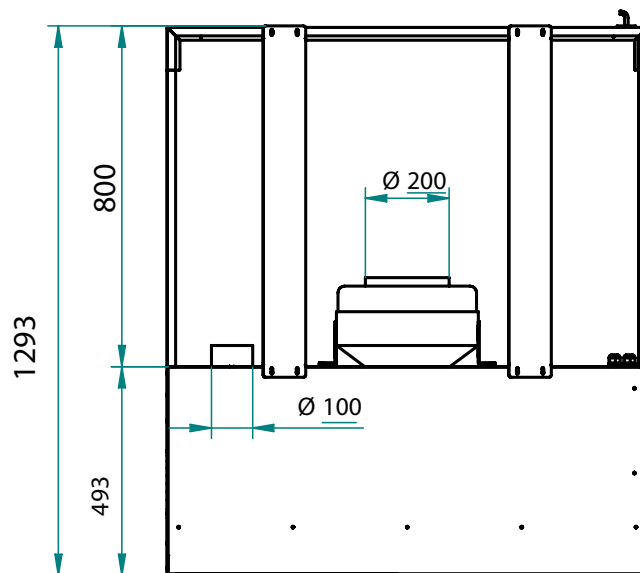

We reserve the right to alter specifications without notice.

KING 6G - SINGLE DECK STAND

FOR KING6GTR400

AFOPIEDAZ6NR1M

FRONT

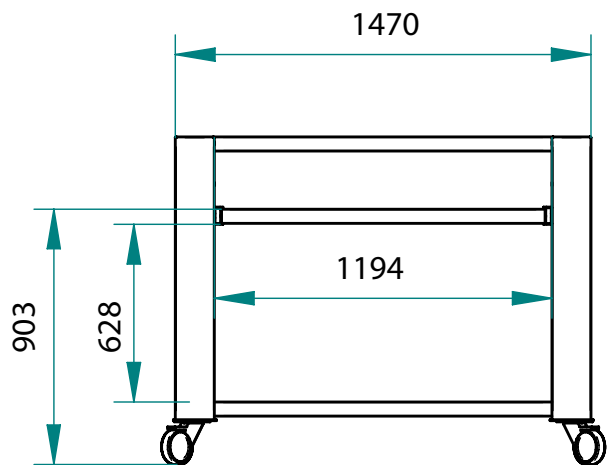

SIDE

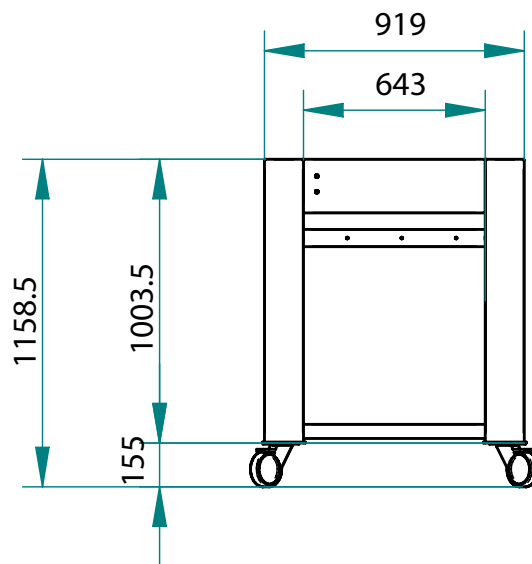

TOP

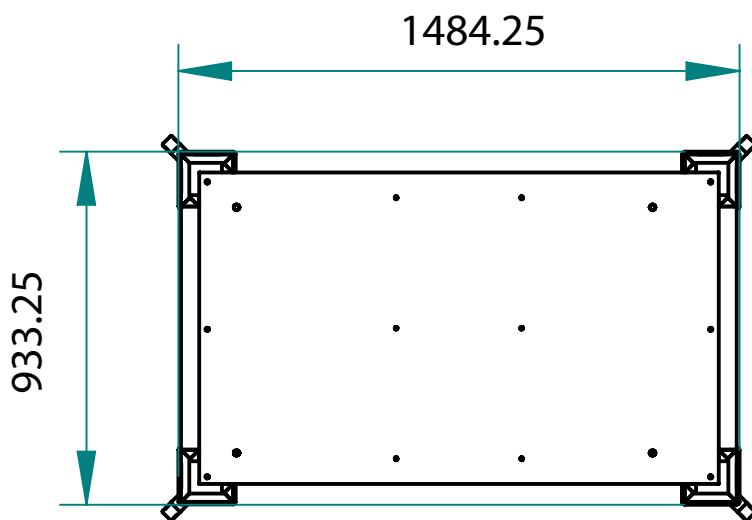

We reserve the right to alter specifications without notice.

KING 6G - DOUBLE DECK STAND

FOR KING6GTR400

AFOIEDAZ6NR2M

FRONT

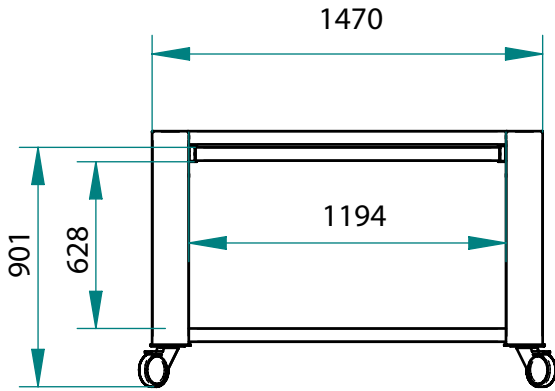

SIDE

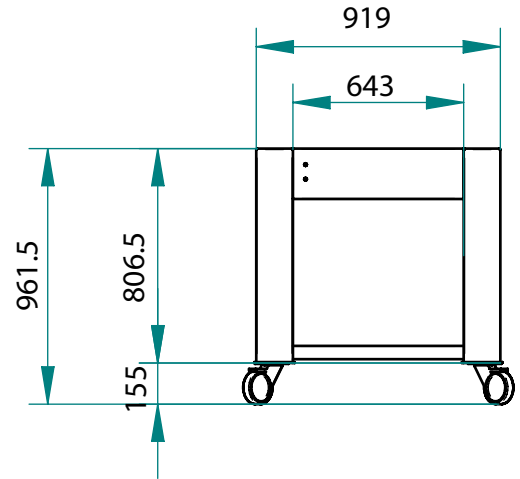

TOP

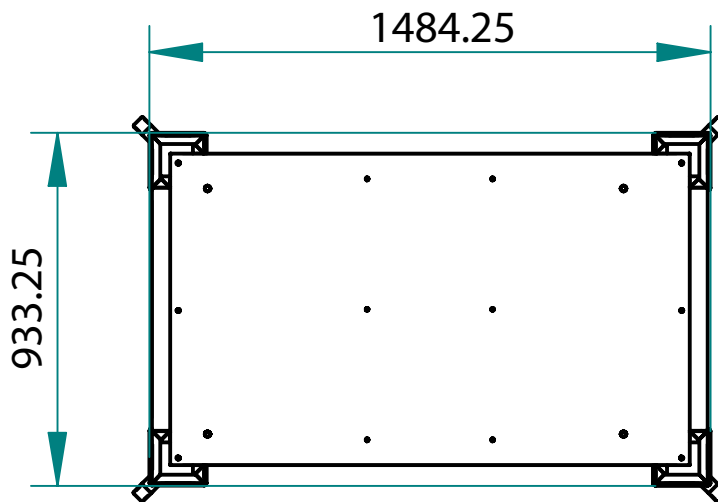

We reserve the right to alter specifications without notice.

KING 6G - TRIPLE DECK STAND

FOR KING6GTR400 AFOPIEDAZ6NR3M

FRONT

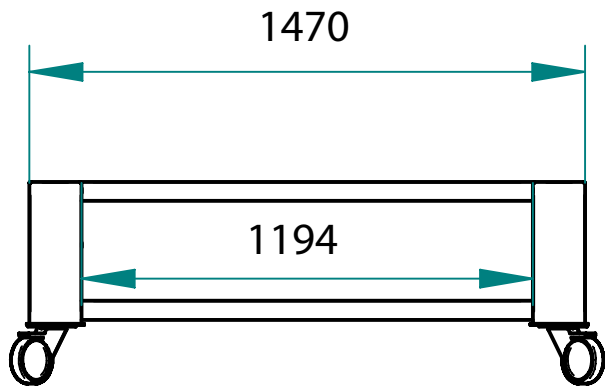

SIDE

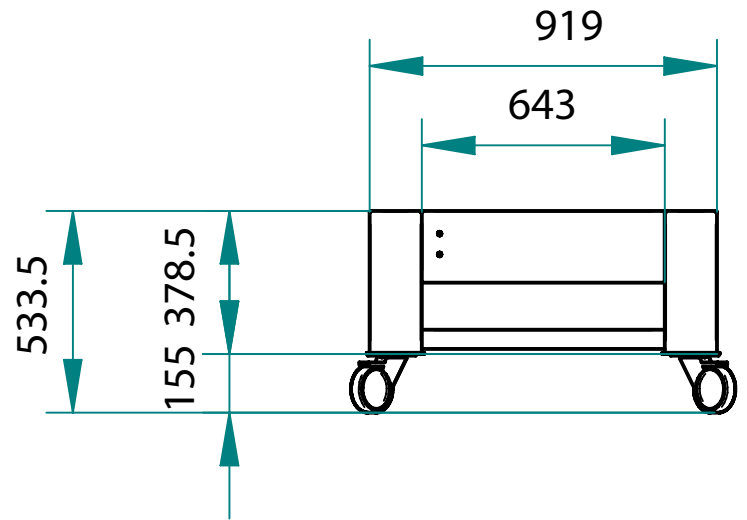

TOP

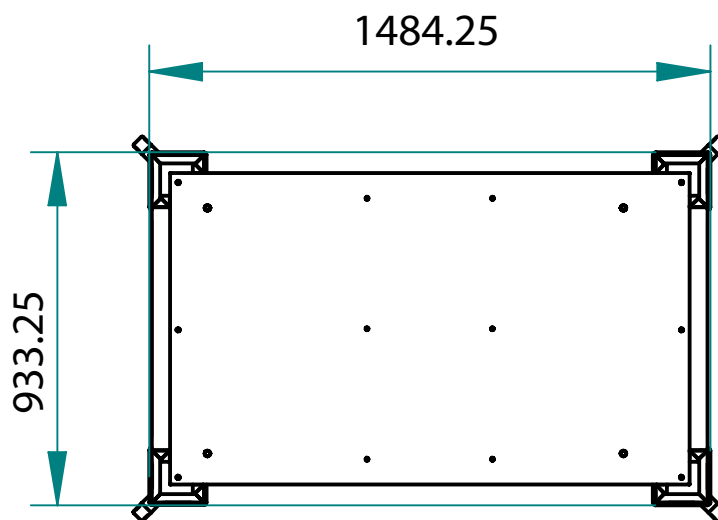

We reserve the right to alter specifications without notice.

KING 6G -
FOR KING6GTR400

DOUBLE DOOR PROOFER
AFOCELUN

FRONT

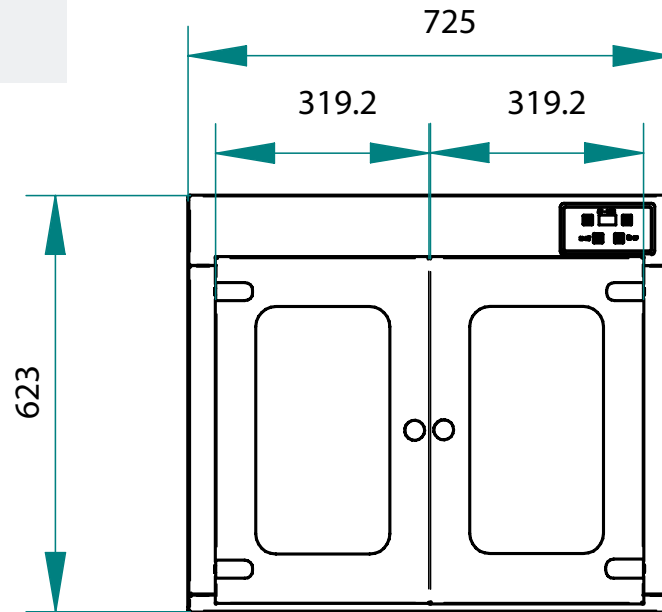

TOP

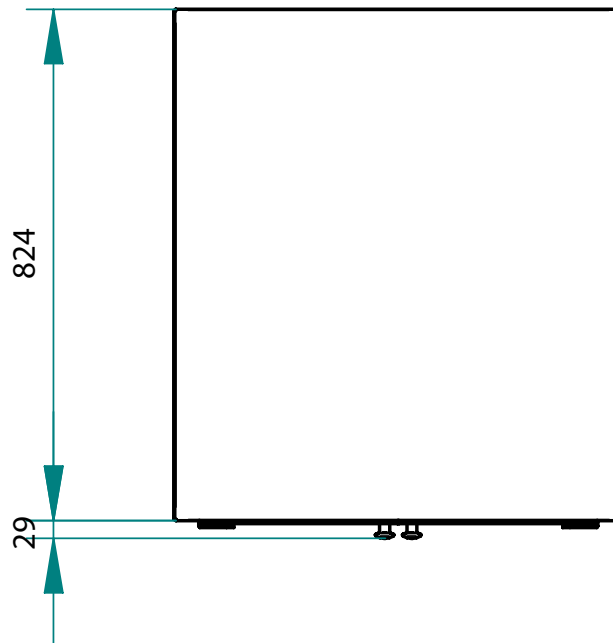

We reserve the right to alter specifications without notice.



WA DEALER
PRACTICAL PRODUCTS PTY LTD

PH: 08 9302 1299
51 Paramount Dr Wangara WA 6065
sales@practicalproducts.com.au
www.practicalproducts.com.au