

HOBART

WAREWASHING
UNDERCOUNTER DISHWASHERS **FP**



PREMAX FP



The premium model with integrated drying provides a perfect drying result. With a water consumption of just 1.0 litre, the **PREMAX FP** is the most economical undercounter dishwasher on the market. It is also the only undercounter dishwasher that can use hot waste steam to manage extremely high levels of soil deposits on wash ware.

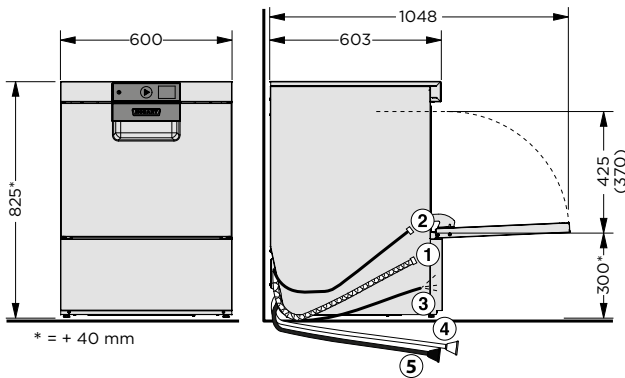

CONNECTIONS

① Drain hose	2,000 mm ID20/OD25
② Supply hose	2,000 mm R 3/4"
Required flow rate	5 l/min
Flow pressure	0.5 (0.8 with softener) - 6 bar
Max. supply water temperature	60 °C
③ Power cord	2,000 mm
Supply hose for	
④ Detergent	2,500 mm
⑤ Rinse aid	2,500 mm

TECHNICAL DATA

Cycle times*	80 / 150 / 170 sec. and special cycles
Water consumption	1 l/rack
Tank capacity	10.6 l
Tank heating	0.8 kW
Power supply	415 / 50 / 3N (240 / 50 / 1)

BOOSTER LOADING

Standard	6.2 kW
Alternative	4.1 kW

TOTAL LOADING

Standard	7.7 kW 3 x 15 A
Alternative	5.6 kW 25 A
Wash pump	0.6 kW 350 l/min
Rack size	500 x 500
Loading height	425 (370) mm**
Noise level	60.5 dB (A)
Weight (gross / net)	70 / 60 kg

* Thermostop guarantees required temperatures with cold water connection, the actual cycle times extend accordingly. For machine protection the water hardness should not exceed 3°dH, if higher we recommend using an integrated water softener or an external water softener of the product line HYDROLINE PROTECT. To avoid spots and streaks on the wash ware, we recommend the usage of a demineralisation cartridge (HYDROLINE STAR / STAR EXTRA) or a reverse osmosis system HYDROLINE PURE.

** Machines with TOP-DRY are restricted in the left rear corner

PRODUCT ADVANTAGES

- **TOP-DRY drying:** integrated drying technology - no need for manual drying and polishing
- **VAPOSTOP²:** integrated steam condensation allows door opening without steam cloud. Also no steam escape during the condensation phase
- **VISIOTRONIC-TOUCH control:** colour touch screen (displays text and graphic) in conjunction with single-button control and remaining cycle time indication
- **WASHSMART app:** controlling your warewash operation with smart technology: status and messages, usage and operating costs, hygiene, service and consumables order
- **Eco programme:** switchable steam rinse cycle reduces fresh-water consumption to 1.0 l. Saving of up to 60 % water and detergent as well as up to 60 % rinse aid
- **SENSO-ACTIVE resource management:** constantly measures the quality of the wash water and keeps the amount of rinsing needed in each rinse cycle to the minimum in order to guarantee a fully hygienic wash result. This reduces the amount of fresh water used per rinse cycle to up to 1.0 l
- **2IN1 double rack system:** two racks can be washed in a single wash cycle. One rack of cups can be washed underneath, while a second rack containing dishes and cutlery can be washed above it. Thanks to the optimum use of the entire wash chamber the performance of the machine can be doubled
- **CLIP-IN wash and rinse arms:** wash and rinse arms can be removed with one hand and without any tools
- **Intelligent data documentation:** automatic recording of important operational data and consumptions and indication on the display
- **USB-interface:** comfortable download of operational data in form of a protocol via USB
- **GENIUS-X² fine filter system:** advanced filter system with pre-wash function reduces detergent consumption up to 35%
- **Interlocked strainer:** prevents operation without tank strainer
- **Optional refill signal:** monitors contents of external as well as integrated chemical containers
- **Hygiene programme:** for removal of calcium carbonate and other deposits from wash chamber