



Icematic introduces a new range of full cube ice machines, with fully electronic functions, that respects the most stringent **anti-pollution parameters** by using **Propane natural gas (R290)**.

Self contained ice maker.

Up to 63kg production per 24/hr of medium ice cube.
42kg storage bin.

Complete with legs, water & drain hoses + 1 ice scoop.
10 AMP power supply.

291 mm drain height including legs to finished floor.



ICE PRODUCTION

Air Cooled Unit

| Air Temp. | | Water Temperature | | | |
|-----------|--|-------------------|-----------|-----------|-----------|
| | | 32° | 21° | 15° | 10° |
| °C | | 32° | 21° | 15° | 10° |
| °F | | 90° | 70° | 60° | 50° |
| 10° | | 63 | 67 | 69 | 70 |
| 50° | | 139 | 148 | 152 | 154 |
| 21° | | 57 | 61 | 63 | 65 |
| 70° | | 126 | 134 | 139 | 143 |
| 32° | | 52 | 56 | 58 | 60 |
| 90° | | 115 | 123 | 128 | 132 |
| 38° | | 42 | 45 | 47 | 49 |
| 100° | | 93 | 99 | 104 | 108 |

Water Cooled Unit

| Air Temp. | | Water Temperature | | | |
|-----------|--|-------------------|-----------|-----------|-----------|
| | | 32° | 21° | 15° | 10° |
| °C | | 32° | 21° | 15° | 10° |
| °F | | 90° | 70° | 60° | 50° |
| 10° | | 64 | 71 | 73 | 75 |
| 50° | | 141 | 157 | 161 | 165 |
| 21° | | 61 | 68 | 70 | 72 |
| 70° | | 134 | 150 | 154 | 159 |
| 32° | | 59 | 64 | 68 | 70 |
| 90° | | 130 | 141 | 150 | 154 |
| 38° | | 54 | 59 | 62 | 63 |
| 100° | | 119 | 130 | 137 | 139 |

CUBE TYPE

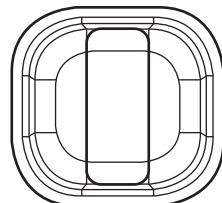
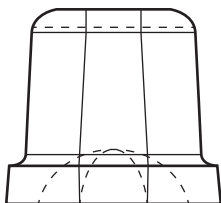

20g weight BRIGHT CUBE

32mm x 35mm x 37mm

The Bright Ice Cube, appreciated for its versatility, is perfect for use in ice buckets, whiskey on the rocks, cocktails and appetisers. The crystal clear appearance of the Bright Cube makes it essential when a high quality is required.

CONTROL PANEL

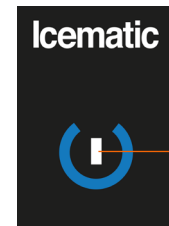

Start-standby Switch
Status Led

BIN CAPACITY

42 Kg - 93 lbs | 2100 pcs

DIMENSIONS

W x D x H (mm)

700 x 580 x 910/1030

740 x 640 x 1080

OPERATING REQUIREMENTS

Rejected Heat 1938 W

Air Volume 310 m³/h















220-240/50/1



R290 GWP = 3

| MIN | | MAX | |
|----------------|--|----------------|--|
| 10°C (50°F) | | 40°C (104°F) | |
| 5°C (41°F) | | 35°C (95°F) | |
| - 10 % | | + 10 % | |
| 1 Bar (14 psi) | | 5 Bar (70 psi) | |

SPECIFICATIONS

| |  cond |  comp. W |  ABS. W |  Fuse |  kWh/100kg |  L / hr |  kg |  lbs |  kg |  lbs |  Ton CO ₂ equiv. |
|------------------|--|---|--|--|---|--|--|---|--|---|--|
| CS70 ZP A |  | 1315 | 620 | 10 | 20.9 | 10.3 | 53 | 117 | 62 | 137 | 0 |
| CS70 ZP W |  | 1315 | 490 | 10 | 18.3 | 45.8 | 53 | 117 | 62 | 137 | 0 |

Vista frontale
Front view

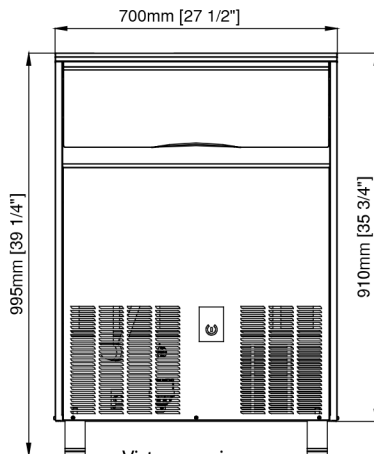

Vista laterale
Lateral view

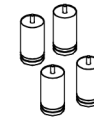
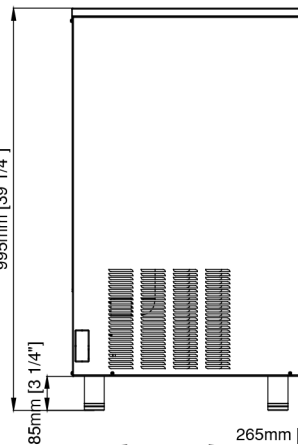

Kit 4 Feet Optional
Kit 4 piedini Optional
Ø50mm H100-120 mm

Vista superiore
Top view

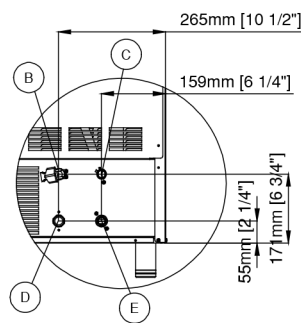
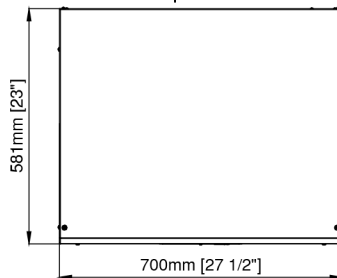

- B** Electrical cable supply / Ingresso alimentazione elettrica
- C** Water outlet connection / Attacco scarico acqua diam. 20 mm

- D** Water outlet connection water condensation / Uscita acqua condensatore ad acqua diam. 20 mm
- E** Water inlet connection / Attacco entrata acqua - 3/4"gas

WA DEALER
PRACTICAL PRODUCTS PTY LTD

PH: 08 9302 1299
51 Paramount Dr Wangara WA 6065
sales@practicalproducts.com.au
www.practicalproducts.com.au

R290