

LIGHT DUTY COMMERCIAL MICROWAVE OVEN
100 OR LESS USES PER DAY

Light Duty Microwaves are ideal for light volume sites recommended for 100 or less uses per day. These dependable ovens are easy to use and are the perfect replacement for domestic ovens in any foodservice operation.

The RCS511TS is a commercial microwave for light duty food service. 100 programmable menu settings and a 4 stage cooking option.



DIMENSIONS

External dimensions: 559W x 483D x 352H mm

Internal cavity: 368W x 381D x 216H mm

POWER SUPPLY

240V 50Hz 10A single phase

TECHNICAL DATA

Power output: 1100 watts

Internal cavity volume: 34 litres

External cabinet finish: Stainless steel

Internal cavity finish: Stainless steel with sealed-in ceramic base

Memory programs: 100

Power levels: 5

Product weight: 19 kg

Shipping weight: 22kg

Magnetrons: 1

SPECIFICATIONS ARE SUBJECT TO CHANGE WITHOUT NOTICE.

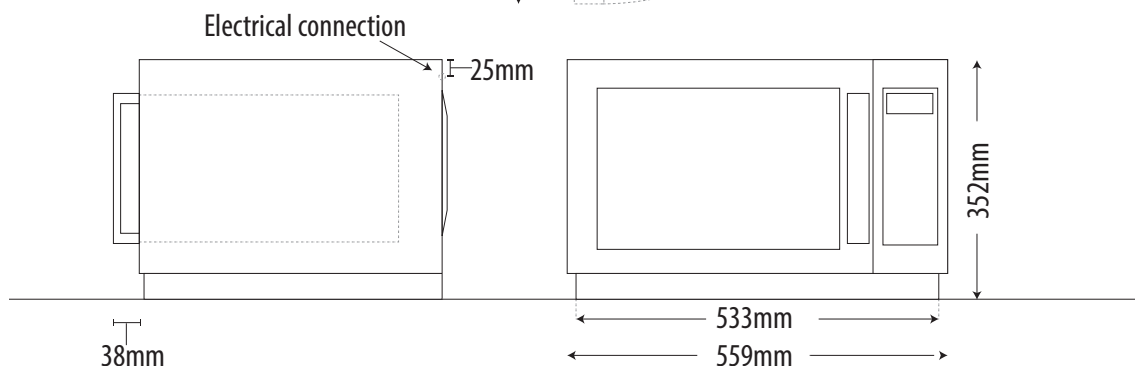
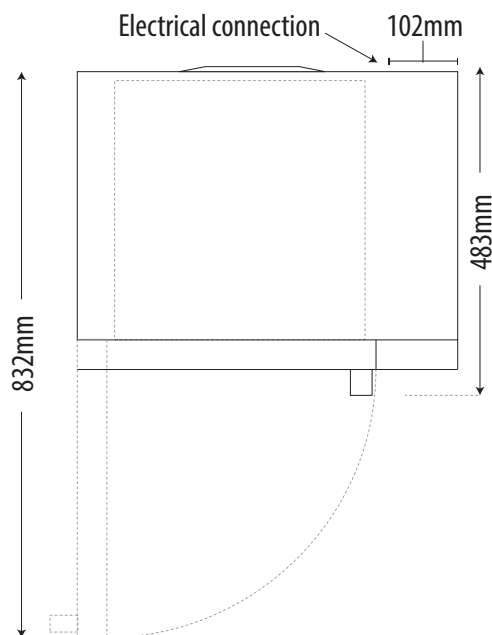

WA DEALER
PRACTICAL PRODUCTS PTY LTD

PH: 08 9302 1299
51 Paramount Dr Wangara WA 6065
sales@practicalproducts.com.au
www.practicalproducts.com.au