

## MAR Series Scale Ice Maker – up to 480kg

**MAR 76 AS** Scale Ice thickness – 1-2mm, residual water content 2%



Scale ice - 1-2mm, residual water content 2%



Note: Ice production rate is measured with the water temperature at 10°C and an ambient temperature of 21°C.

- Up to 480kg daily production capacity
- Scale ice machine, in “compact system” version, built in unit
- Head only ice maker, requires a separate storage bin to store ice product
- Air Cooled version
- AISI304 Stainless steel evaporating drum and ice scraper blade
- Low-water sensor protection
- Drive motor / gear reducer with V-Belt drive
- Plug and work technology
- On/off manual switch, with weekly programmable timer
- Water in / ice out concept limits excess energy, water and time wastage
- Agion Technology resists the growth of microbes and the development of unpleasant odours

- Simple, reliable electromechanic controls
- Resistant stainless steel exterior
- Easy access front condenser air filter
- External indicator lights to show operation status
- Includes water and drain hose

#### Recommended Storage Bins

- UBH 1100 – Upright storage bin with 553kg storage capacity

## MAR Series Scale Ice Maker – up to 480kg

### MAR 76 AS

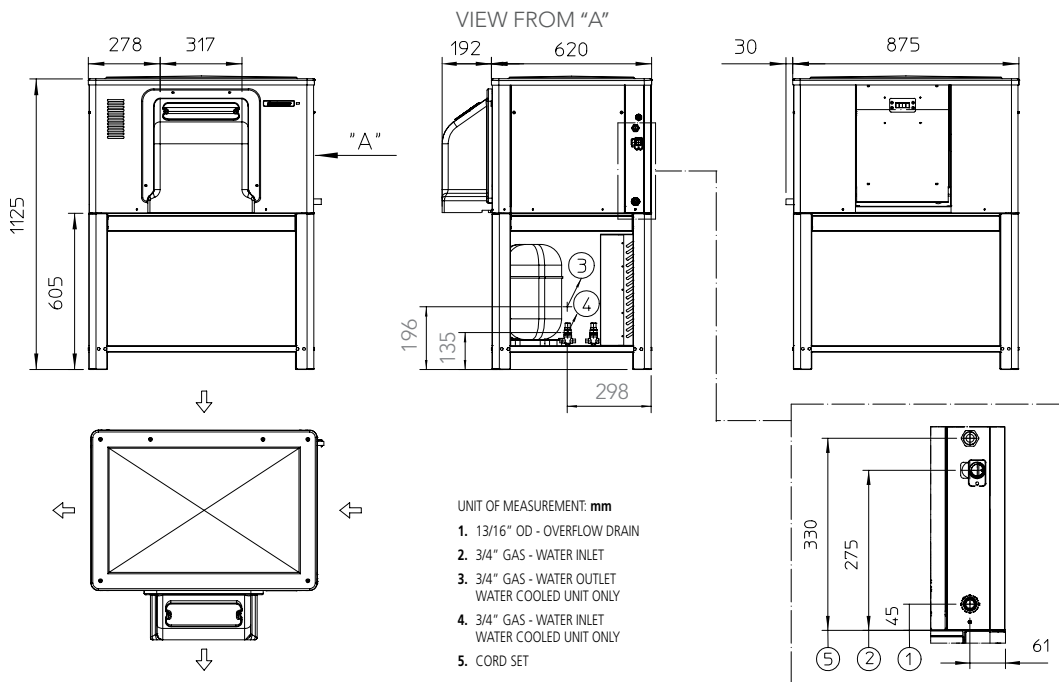

#### Ice production per 24 hours

Ambient temperature / Water temperature

10°C / 10°C	21°C / 10°C	32°C / 21°C
1mm: 510	1mm: 480	1mm: 400
2mm: 459	2mm: 432	2mm: 360

#### Refrigerant type

R404A

#### Installation distance from wall

Rear 100mm  
Sides 150mm

Operating requirement air temperature 10-43°C

#### Dimensions

Width: 905mm  
Depth: 812mm  
Height: 1125mm  
Nett weight: 186kg  
Packed weight: 203kg

#### Water connection requirements

Inlet connection: R 3/4"  
Cold water: 5-35°C  
Pressure: 100-500kPa  
Water outlet connection: Ø3/4"

#### Water consumption

Air cooled version: 16.5 litres per hour

#### Electrical rating

Air cooled version: 400-415V, 3P+N+E, 50Hz, 2500W,  
16A cord supplied

No. Circuit wire: 5  
Compressor: 2250W  
Energy consumption: 60kW/24hr

**WA DEALER**  
**PRACTICAL PRODUCTS PTY LTD**

PH: 08 9302 1299  
51 Paramount Dr Wangara WA 6065  
sales@practicalproducts.com.au  
www.practicalproducts.com.au