

IRINOX

The Freshness Company®



Item No.:

Qty.:

Project:

EF NEXT M

The essential, easy and safe Irinox blast chiller



The Irinox rapid blast chiller cools quickly to +3°C and deep freezes food at -18°C at the core, even hot ones just removed from the oven. The operating principle of a blast chiller is to extract the heat from the food in the shortest possible time. EF Next guarantees ultra-rapid cooling and freezing and preserves the fragrance, consistency, colours and all food nutritional properties, fixing its quality and freshness longer over time.

Yield

Rapid blast chilling cycle capacity (90/+3°C) kg 38,0

Rapid freezing cycle capacity (90/-18°C) kg 35,0

Tests carried out in compliance with the Irinox procedure using 5-cm thick beef

Capacity

Number of trays: 18 x GN1/1 o 600x400 (H= 20 mm)

Number of trays: 12 x GN1/1 o 600x400 (H= 40 mm)

Number of trays: 9 x GN1/1 o 600x400 (H= 65 mm)

Optional

- Door opening on the right with hinges on the right.
- Adjustable lowered feet H 80 - 115 mm.
- 4 wheels, 2 of which with brake.
- Sanigen® (Irinox patented sanitization system).
- Pair of additional GN1/1 and 600x400 mm guides
- Special voltages on request
- Packing in HT wooden case.

Product warranty

- 2 years from the date of installation, after sending the installation report, on the parts (see warranty condition)

Operation

- EF Next's cooling cycles lower to +3°C the core temperature of the food, introduced at any temperature, even as soon as it is out of the oven, and quickly cross the band of maximum bacterial proliferation, the cause of their natural ageing.
- EF Next has two cycles dedicated to cooling. DELICATE +3°C: suitable for the most delicate products such as mousses, creams, fish, rice, vegetables and more generally food of reduced thickness and with a high water content. STRONG + 3°C: ideal for fat, very dense, large-sized or packaged products, such as meats, soups, sauces.
- EF Next's freezing cycles transform the water contained in food into microcrystals that preserve its structure and quality for longer. EF Next has 2 freezing cycles. DELICATE -18°C, works in two phases, one at positive temperature and the other negative, and is recommended for leavened bakery products or for bread; STRONG -18°C: quickly freezes medium-large products up to -18°C in the core, with an air temperature reaching -35°C. Also ideal for fixing the structure of ice cream.
- Automatic recognition of manual work mode (timed) or automatic mode (with probe).

Standard construction details

- Door opening on the left with hinges on the left.
- Patented concealed hinges.
- Full height door with double bevelled side edges.
- Door opening up to 160°.
- 115° opening for side-by-side machines, shockproof (on request).
- Magnetic and slow closing of the door.
- Equipped with 10-chamber gasket designed for high and low temperatures.
- Large magnetic flat surface (400x150 mm) to fix the core probe.
- Core probe with one detection point with quick screw connector, anti-corrosion, watertight IP67.
- Easy removal and cleaning of the condenser filter thanks to the tilting grill.
- Ergonomic and robust handle made of steel.
- 4.3' resistive colour touch-screen display with intuitive icons and controls; in just 3 steps it allows you to start the cooling or freezing cycles.
- IRINOX BALANCE SYSTEM®: is the design system created by Irinox, applied to the whole range of blast chillers. Compressor, condenser, evaporator and ventilation are balanced to interact perfectly with each other. The goal of "Irinox Balance System" is to always guarantee the freshness and original quality of the product.
 - Condenser: designed by Irinox, it guarantees the performance declared in Climate Class 4.
 - Evaporator: designed by Irinox, protected from the corrosive action of food with a cataphoresis treatment.
 - Ventilation: use of high efficiency one-speed fans.
 - Compressor: high efficiency and performance, chosen from the reference brands on the market.
- 304 stainless steel internal and external material.
- Built-in air condensation.
- R452A refrigerant gas.
- MultiRack®, the patented adjustable tray holder that doubles the number of trays for each model and improves air circulation inside the blast chiller.
- 10 pairs of guides included.
- Maximum cleanliness and hygiene thanks to the rounded corners and components in the chamber.
- USB port for HACCP data download.

EF NEXT M

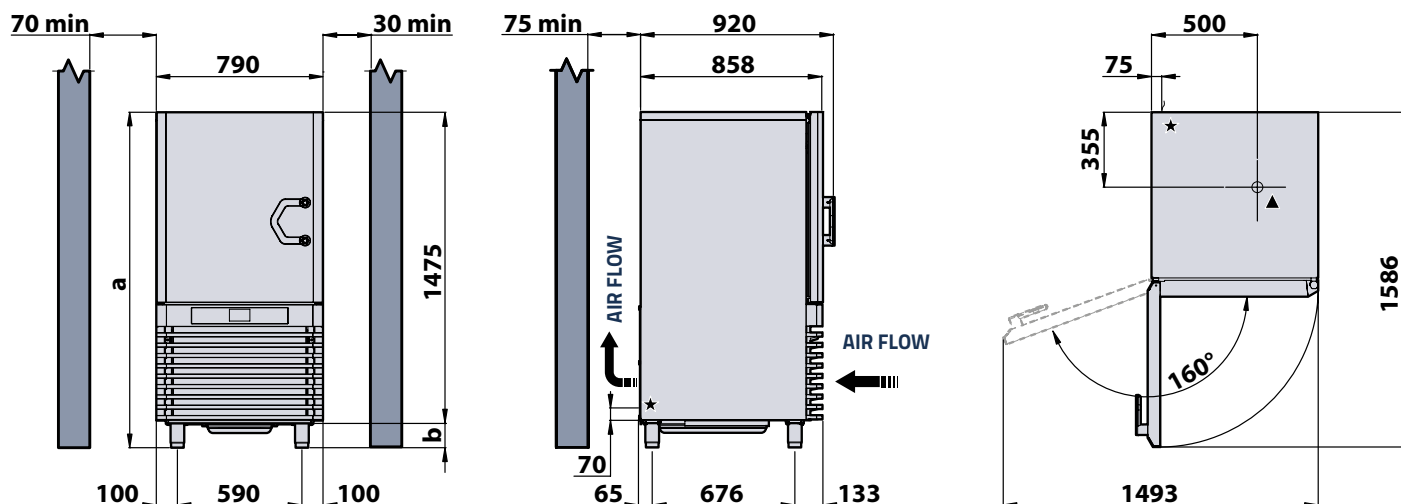

HEIGHT

		a	b
Standard feet	mm	1590	115 ÷ 165
Lowered feet option	mm	1555	80 ÷ 115
Castors option	mm	1630	155

Measurement in millimeters

- ★ Main power cable
- ▲ Drain pipe (corrugated flexible hose $\varnothing 32\text{mm}$)

TECHNICAL SPECIFICATIONS

Power supply	-	400V-3N 50Hz	200V-3 50/60Hz
Maximum operating power consumption	W	2700	3000 / 3600
Power consumption	A	4,4	12.3 / 12.5
Main power cable	mm ²	5G2.5	4G1.5
Compressor rating	HP	1,5	2,0
Cooling power (-10/+40°C; Tsuct +20°C; Subcooling OK)	W	3987	4105 / 4750
Condensing power (-10/+40°C; Tsuct+20°C; Subcooling OK)	W	5871	6375 / 7720
Minimum air exchange	m ³ /h	3100	3000 / 3300
Coolant type	-	R452a	R404a
Nominal coolant quantity	kg	1,7	2,0
Climate class	-	4	4
Dimension (WIDTH x DEPTH)	mm	790 x 1015	
Internal cell dimension (WIDTH x DEPTH x HEIGHT)	mm	650 x 420 x 795	
Cabinet weight	kg	160	160
Noise (5M)	dB(A)	77	- / -

ENERGY CONSUMPTION ACCORDING TO EN 17032

Model	EF_NEXT_M (400V-3N+PE 50Hz)	
Type of product	Blast chiller / Blast freezer	
Chilled full load capacity	kg	38
Frozen full load capacity	kg	35
Energy consumption Blast chilling cycle (STRONG +3 °C)	kWh/kg	0,0870
Energy consumption Blast freezing cycle (STRONG -18 °C)	kWh/kg	0,1660
Blast chilling cycle from/to +65 °C / +10 °C	min	93
Blast freezing cycle from/to +65 °C / -18 °C	min	232

INSTALLATION

The blast chiller must be installed by following and complying with the contents of the specific installation manual. The content of the manual must be carefully followed to ensure correct operation and to protect the rights of the user based on the warranty.

Continuous product development may require changes to specifications without notice.