

Technical data sheet for

# ELECTRIC SALAMANDER

SN8200E

---



- Powerful 6kW infra-red elements
- Left and right heat control
- Branding plate option
- Wall mounting bracket
- Easy to clean
- Easy service

## Overall Construction

- Monocoque construction
- External panels of 0.9mm 304 grade stainless steel
- Stainless steel tray under grilling area with grease trough
- Two 3kW infra-red elements

## Racking

- Four position racking (flat or inclined)
- Adjustable chrome wire rack with heat resistant handles

## Controls

- Large easy use controls
- Heat resistant reinforced control knobs
- Indicator light for each element on
- Recessed front panels for hand and control protection
- Each side controlled by a 3 heat switch

## Cleaning and Servicing

- Access to all parts from front of unit
  - Stainless steel and vitreous porcelain enamel surfaces used throughout
-

Technical data sheet for  
**ELECTRIC SALAMANDER**

**Specifications**

**Elements**

2 x 3kW

**Electrical requirements**

230-240V, 1P+N+E, 50/60Hz, 6kW, 25A

**DIMENSIONS**

Width 900mm

Depth 424mm

(455mm with wall mounting bracket)

Height 456mm

**COOKING AREA**

Rack size 610mm x 310mm, 1890cm<sup>2</sup>

Branding Plate 610mm x 310mm, 1890cm<sup>2</sup>

**NETT WEIGHT**

36kg

**PACKING DATA**

0.31m<sup>3</sup>, 63kg

Width 945mm

Depth 520mm

Height 635mm

**ELECTRICAL CONNECTION**

230-240V 1 phase hard wired via terminal block at back of unit 64mm from right side and 90mm from bottom of unit

**OPTIONS AT EXTRA COST**

100mm high feet for bench mounting  
Branding kit - includes one double-sided, ribbed cast aluminium branding plate

**SN8200E**

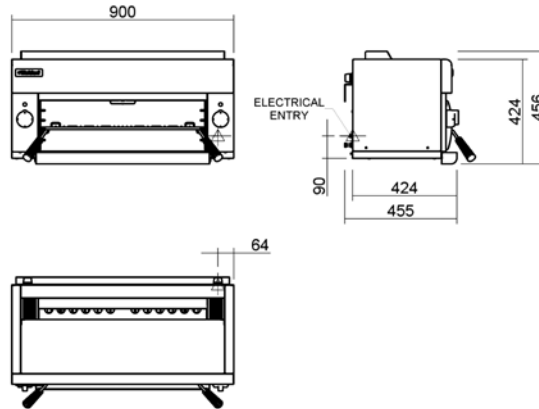

**WA DEALER**  
**PRACTICAL PRODUCTS PTY LTD**

PH: 08 9302 1299  
51 Paramount Dr Wangara WA 6065  
sales@practicalproducts.com.au  
www.practicalproducts.com.au