

GC2RGDSL

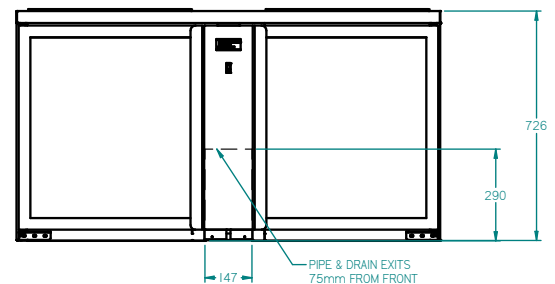

CATEGORY	GENERAL COUNTERS & BACK BARS
RANGE	Glass chiller
UNIT	REFRIGERATOR
TYPE	REMOTE
DOORS	2

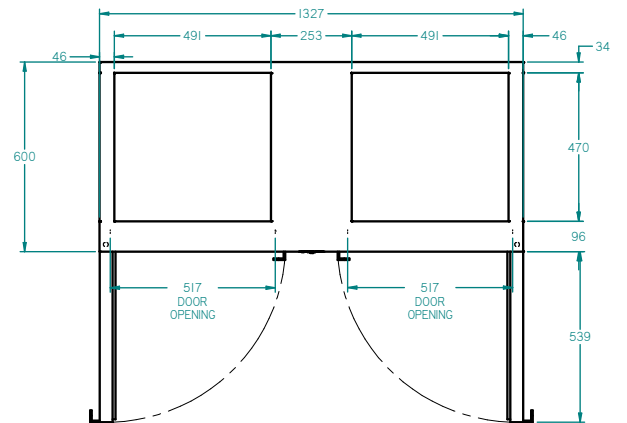
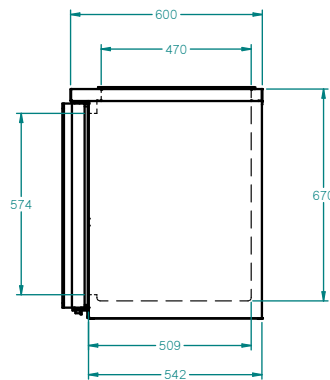

SPECIFICATIONS

CAPACITY - BASKETS/DOOR (NOT INCLUDED) (BASED ON 150MM H GLASSES)	3 Baskets
TEMPERATURE	1°C / 4°C
SPRING LOAD	YES
DIMENSIONS - W X D X H (ON 150MM H LEGS) MM	1327 W x 600 D x 875 H
WEIGHT UNPACKED (KG)	100

STANDARD INCLUSIONS ***

DOOR TYPE	Standard: GD (Glass Door)
FINISH (INTERIOR AND EXTERIOR EXCLUDING REAR AND UNDER)	SS (Stainless Steel)
SPRING LOADING CAGE	2

ELECTRICAL

POWER SUPPLY	10 amp
POWER CABLE LENGTH (METRES)	2
RUNNING AMPS	0.5

GAS TYPE

REFRIGERANT	R404a
-------------	-------

REFRIGERATION WATTAGES FOR REMOTE UNITS

REMOTE WATTAGES	750 @ -5° C SST
-----------------	-----------------

WA DEALER
PRACTICAL PRODUCTS PTY LTD

PH: 08 9302 1299
51 Paramount Dr Wangara WA 6065
sales@practicalproducts.com.au
www.practicalproducts.com.au